



# Dell™ PowerEdge™ 6600 Systems Installation and Troubleshooting Guide

[Introduction](#)  
[Indicators, Messages, and Codes](#)  
[Finding Software Solutions](#)  
[Running the System Diagnostics](#)  
[Troubleshooting Your System](#)  
[Installing System Options](#)  
[Installing Drives](#)  
[Getting Help](#)  
[Jumpers and Connectors](#)  
[Abbreviations and Acronyms](#)

---

## Notes, Notices, and Cautions

-  **NOTE:** A NOTE indicates important information that helps you make better use of your computer.
  -  **NOTICE:** A NOTICE indicates either potential damage to hardware or loss of data and tells you how to avoid the problem.
  -  **CAUTION:** A CAUTION indicates a potential for property damage, personal injury, or death.
- 

Information in this document is subject to change without notice.  
© 2001 Dell Computer Corporation. All rights reserved.

Reproduction in any manner whatsoever without the written permission of Dell Computer Corporation is strictly forbidden.

Trademarks used in this text: *Dell*, the *DELL* logo, *PowerEdge*, *Dell OpenManage*, *Dimension*, *Inspiron*, *Dell Precision*, *OptiPlex*, *Latitude*, and *DellNet* are trademarks of Dell Computer Corporation; *MS-DOS* is a registered trademark of Microsoft Corporation.

Other trademarks and trade names may be used in this document to refer to either the entities claiming the marks and names or their products. Dell Computer Corporation disclaims any proprietary interest in trademarks and trade names other than its own.

---

*Initial release: 25 Feb 02*

## Jumpers and Connectors

### Dell™ PowerEdge™ 6600 Systems Installation and Troubleshooting Guide

- [Jumpers—A General Explanation](#)
- [I/O Riser Card Jumpers and Connectors](#)
- [I/O Board Connectors and Buses](#)
- [Microprocessor Board Connectors](#)
- [SCSI Backplane Board Connectors](#)
- [Peripheral Riser Card Connectors](#)
- [Disabling a Forgotten Password](#)

This section provides specific information about the jumpers on the system board. It also provides some basic information on jumpers and switches and describes the connectors and sockets on the various boards in the system.

---

## Jumpers—A General Explanation

Jumpers provide a convenient and reversible way of reconfiguring the circuitry on a printed circuit board. When reconfiguring the system, you may need to change jumper settings on the system board. You may also need to change jumper settings on expansion cards or drives.

### Jumpers

Jumpers are small blocks on a circuit board with two or more pins emerging from them. Plastic plugs containing a wire fit down over the pins. The wire connects the pins and creates a circuit. To change a jumper setting, pull the plug off its pin(s) and carefully fit it down onto the pin(s) indicated. [Figure A-1](#) shows an example of a jumper.

**Figure A-1. Example Jumpers**

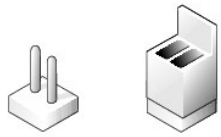

**CAUTION:** Make sure the system is turned off before you change a jumper setting. Otherwise, damage to the system or unpredictable results may occur.

A jumper is referred to as open or unjumped when the plug is pushed down over only one pin or if there is no plug at all. When the plug is pushed down over two pins, the jumper is referred to as jumped. The jumper setting is often shown in text as two numbers, such as 1-2. The number 1 is printed on the circuit board so that you can identify each pin number based on the location of pin 1.

[Figure A-2](#) shows the location and default settings of the jumper blocks on the system board. See [Table A-1](#) for the designations, default settings, and functions of the system's jumpers.

---

## I/O Riser Card Jumpers and Connectors

[Figure A-2](#) shows the location of the configuration jumpers and connector on the I/O riser card. [Table A-1](#) and [Table A-2](#) list the jumpers and connectors.

**Figure A-2. I/O Riser Card Components**

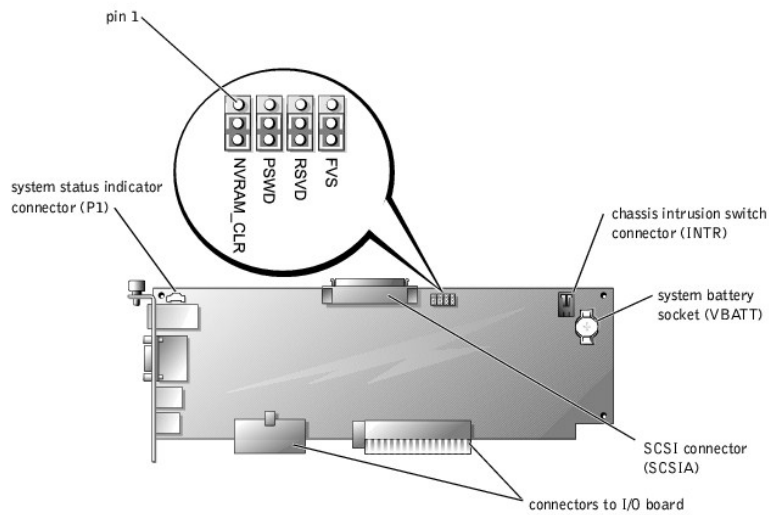







Table A-1. I/O Riser Card Jumper Settings

Jumper	Setting	Description
NVRAM_CLR	 (default)	The configuration settings are retained at system boot.
		The configuration settings are cleared at next system boot. (If the configuration settings become corrupted to the point where the system will not boot, change the jumper setting to 1–2 and boot the system. Change the jumper setting back to 2–3 before restoring the configuration information.)
PSWD	 (default)	The password feature is enabled.
		The password feature is disabled.
RSVD		Reserved ( <i>do not change</i> ).
FVS		Reserved ( <i>do not change</i> ).

**NOTE:** For the full name of an abbreviation or acronym used in this table, see "[Abbreviations and Acronyms](#)."

Table A-2. I/O Riser Card Connectors

Connector or Socket	Description
INTR	Chassis intrusion switch connector
P1	Back-panel system status indicator
SCSIA	An external SCSI connector on the back panel or an internal tape drive
VBATT	System battery socket

**NOTE:** See [Figure 2-3](#) for back-panel connectors provided by the I/O riser card.

## I/O Board Connectors and Buses

[Figure A-3](#) shows the expansion slots, buses, and bus operating speeds.

Figure A-3. I/O Board Connectors and Buses

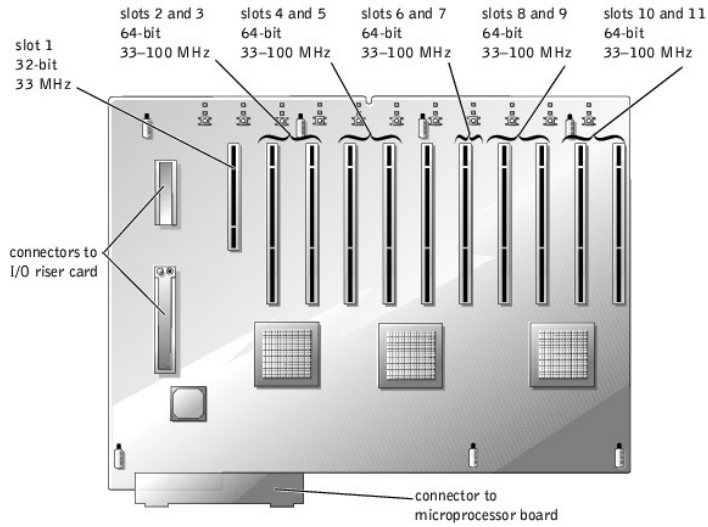

## Microprocessor Board Connectors

See [Figure A-4](#) and [Table A-3](#) for the location and description of the microprocessor board connectors.

**Figure A-4. Microprocessor Board Connectors**

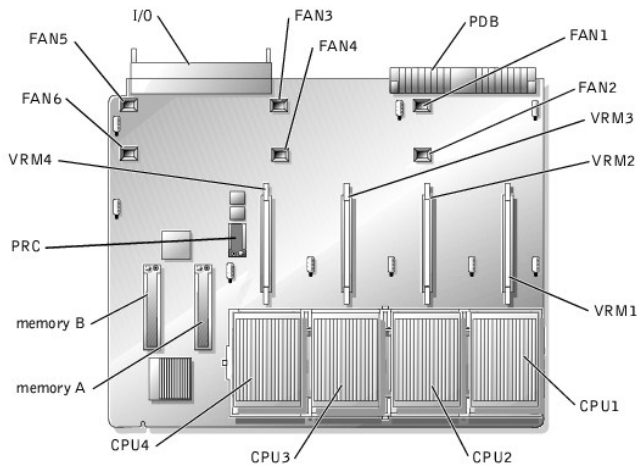

**Table A-3. Microprocessor Board Connectors**

Connector or Socket	Description
I/O	Interface connector for the microprocessor board and the I/O board
FAN $n$	Fan connectors 1 through 6
PDB	Interface connector for the microprocessor board and the power distribution board
VRM $n$	VRM connectors 1 through 4
CPU $n$	Microprocessor sockets 1 through 4
MEMORY $n$	Memory riser card connectors A and B
PRC	Peripheral riser card connector

**NOTE:** For the full name of an abbreviation or acronym used in this table, see "[Abbreviations and Acronyms](#)."

## SCSI Backplane Board Connectors

Figure A-5 shows the location of the connectors on each side of the SCSI backplane board.

Figure A-5. Connectors on the SCSI Backplane Board

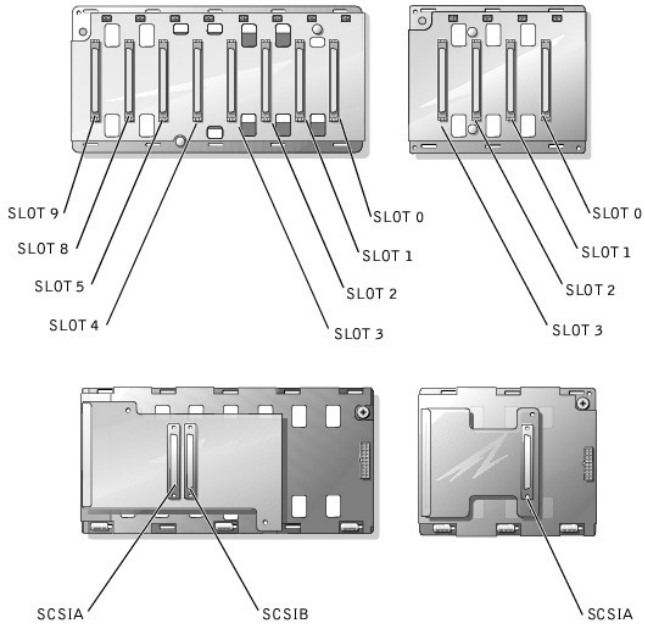

## Peripheral Riser Card Connectors

See Figure A-6 and Table A-4 for the location and description of the peripheral riser card connectors.

Figure A-6. Peripheral Riser Card Connectors

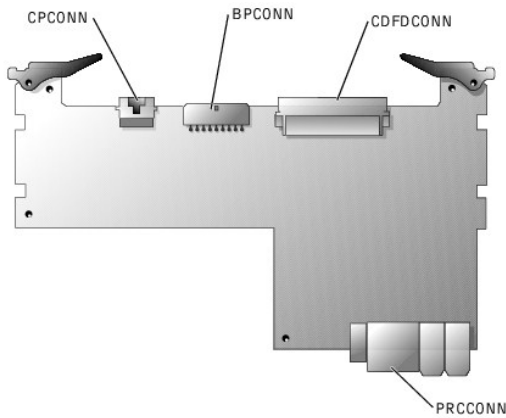

Table A-4. Peripheral Riser Card Connectors

Connector or Socket	Description
CPCONN	Control panel cable connector
BPCONN	Backplane power connector (not used)
CDFDCONN	CD/diskette interface cable connector
PRCCONN	Peripheral riser card connector

**NOTE:** For the full name of an abbreviation or acronym used in this table, see "Abbreviations and Acronyms."

---

## Disabling a Forgotten Password

The system's software security features include a system password and a setup password, which are discussed in detail in "Using the System Setup Program" in the *User's Guide*. A password jumper on the I/O riser card enables these password features or disables them and clears any password(s) currently in use.

To disable a forgotten system password or setup password, perform the following steps.

 **CAUTION:** See "Protecting Against Electrostatic Discharge" in the Safety Instructions in your *System Information* document.

1. Remove the back cover (see "[Removing the Back Cover](#)" in "Troubleshooting Your System").
2. Refer to [Figure A-2](#) for the location of the password jumper (labeled "PSWD") on the I/O riser card.
3. Remove the jumper plug from the PSWD jumper.
4. Replace the back cover, and then reconnect the system to an electrical outlet and turn it on.

The existing passwords are not disabled (erased) until the system boots with the PSWD jumper plug removed. However, before you assign a new system and/or setup password, you must install the jumper plug.

 **NOTE:** If you assign a new system and/or setup password with the jumper plug still removed, the system disables the new password(s) the next time it boots.

5. Repeat step 1.
6. Install the jumper plug on the PSWD jumper (see [Figure A-2](#)).
7. Replace the back cover, and then reconnect the system and peripherals to their electrical outlets and turn them on.
8. Assign a new system and/or setup password.

To assign a new passwords using the System Setup program, see "Assigning a System Password" in the *User's Guide*.

---

[Back to Contents Page](#)

[Back to Contents Page](#)

## Abbreviations and Acronyms

Dell™ PowerEdge™ 6600 Systems Installation and Troubleshooting Guide

### A

ampere(s)

### AC

alternating current

### ADC

analog-to-digital converter

### ANSI

American National Standards Institute

### APIC

Advanced Peripheral Interrupt Controller

### ASIC

application-specific integrated circuit

### BIOS

basic input/output system

### BMC

baseboard management controller

### bpi

bits per inch

### bps

bits per second

### BTU

British thermal unit

### C

Celsius

### CD

compact disc

### CGA

color graphics adapter

### cm

centimeter(s)

### CMOS

complementary metal oxide semiconductor

### COM

communications

### cpi

characters per inch

### cpl

characters per line

**CPU**

central processing unit

**DAC**

digital-to-analog converter

**DAT**

digital audio tape

**dB**

decibel(s)

**dBA**

adjusted decibel(s)

**DC**

direct current

**DDR**

double-data rate

**DIMM**

dual in-line memory module

**DIN**

Deutsche Industrie Norm

**DIP**

dual in-line package

**DMA**

direct memory access

**DOC**

Department of Communications (in Canada)

**dpi**

dots per inch

**DRAC**

Dell™ Remote Access Card

**DRAM**

dynamic random-access memory

**DS/DD**

double-sided double-density

**DS/HD**

double-sided high-density

**ECC**

error checking and correction

**EDO**

extended-data out

**EGA**



enhanced graphics adapter

#### **EIDE**

enhanced integrated drive electronics

#### **EMI**

electromagnetic interference

#### **EMM**

expanded memory manager

#### **EMS**

Expanded Memory Specification

#### **EPP**

Enhanced Parallel Port

#### **EPROM**

erasable programmable read-only memory

#### **ESD**

electrostatic discharge

#### **ESDI**

enhanced small-device interface

#### **ESM**

embedded server management

#### **F**

Fahrenheit

#### **FAT**

file allocation table

#### **FCC**

Federal Communications Commission

#### **ft**

feet

#### **g**

gram(s)

#### **G**

gravities

#### **GB**

gigabyte(s)

#### **GUI**

graphical user interface

#### **Hz**

hertz

#### **I/O**

input/output

#### **ID**

identification

**IDE**

integrated drive electronics

**IRQ**

interrupt request

**K**

kilo- (1024)

**KB**

kilobyte(s)

**KB/sec**

kilobyte(s) per second

**Kb**

kilobit(s)

**Kbps**

kilobit(s) per second

**kg**

kilogram(s)

**kHz**

kilohertz

**LAN**

local area network

**lb**

pound(s)

**LCD**

liquid crystal display

**LED**

light-emitting diode

**LIF**

low insertion force

**LN**

load number

**lpi**

lines per inch

**LVD**

low voltage differential

**m**

meter(s)

**mA**

milliamper(s)

**mAh**

milliamper(s)-hour(s)

**MB**

megabyte(s)

**Mb**

megabit(s)

**Mbps**

megabit(s) per second

**MBR**

master boot record

**MDA**

monochrome display adapter

**MGA**

monochrome graphics adapter

**MHz**

megahertz

**mm**

millimeter(s)

**ms**

millisecond(s)

**MTBF**

mean time between failures

**mV**

millivolt(s)

**NIC**

network interface controller

**NiCad**

nickel cadmium

**NiMH**

nickel-metal hydride

**NMI**

nonmaskable interrupt

**ns**

nanosecond(s)

**NTFS**

NT File System

**NVRAM**

nonvolatile random-access memory

**OTP**

one-time programmable

**PAL**

programmable array logic

**PCI**

Peripheral Component Interconnect

**PCMCIA**

Personal Computer Memory Card International Association

**PDB**

power distribution board

**PDU**

power distribution board

**PGA**

pin grid array

**PIC**

personal identification code

**POST**

power-on self-test

**ppm**

pages per minute

**PQFP**

plastic quad flat pack

**PSDB**

power-supply distribution board

**PS/2**

Personal System/2

**PXE**

preboot execution environment

**RAID**

redundant arrays of independent disks

**RAM**

random-access memory

**RCU**

Resource Configuration Utility

**REN**

ringer equivalence number

**RFI**

radio frequency interference

**RGB**

red/green/blue

**ROM**

read-only memory

**rpm**

revolutions per minute

**RTC**

real-time clock

**SBE**

single bit ECC

**SCSI**

small computer system interface

**sec**

second(s)

**SEC**

single-edge contact

**SEL**

system event log

**SDRAM**

synchronous dynamic random-access memory

**SIMM**

single in-line memory module

**SMB**

server management bus

**SMI**

system management interrupt

**SNMP**

Simple Network Management Protocol

**SRAM**

static random-access memory

**SVGA**

super video graphics array

**TFT**

thin film transistor

**tpi**

tracks per inch

**UMB**

upper memory block

**UPS**

uninterruptible power supply

**USB**

universal serial bus

**V**

volt(s)

**VAC**

volt(s) alternating current

**VDC**

volt(s) direct current

**VGA**

video graphics array

**VLSI**

very-large-scale integration

**VRAM**

video random-access memory

**VRM**

voltage regulator module

**W**

watt(s)

**WH**

watt-hour(s)

**XMM**

extended memory manager

**XMS**

eXtended Memory Specification

**ZIF**

zero insertion force

---

[Back to Contents Page](#)

[Back to Contents Page](#)

## Introduction

### Dell™ PowerEdge™ 6600 Systems Installation and Troubleshooting Guide

- [Other Documents You May Need](#)
- [Obtaining Technical Assistance](#)

Your system is a high-speed server that offers significant service and upgrade features. The system includes the following service features to make troubleshooting and repair easy and effective:

- 1 Embedded server management hardware, which monitors temperatures and voltages throughout the system and notifies you if the system overheats, if a system cooling fan malfunctions, or if a power supply fails
- 1 Redundant, hot-pluggable cooling fans and power supplies
- 1 System diagnostics, which checks for hardware problems (if the system can boot)

The following system upgrade options are offered:

- 1 Additional microprocessors
  - 1 Additional memory
  - 1 A variety of PCI and PCI-X expansion-card options (including RAID controller cards)
  - 1 A remote access PCI expansion card for system management
- 

## Other Documents You May Need

Besides this *Installation and Troubleshooting Guide*, the following documentation is included with your system:

- 1 The *Setting Up Your System* sheet provides general instructions for setting up your system.
- 1 The *System Information* document provides important safety and regulatory information. Warranty information might be included within this document or as a separate document.
- 1 The *Rack Installation Guide* describes how to unpack, set up, and install your system in a rack.
- 1 The *User's Guide* describes system features and technical specifications, video and SCSI device drivers, the System Setup program, and software support utilities.
- 1 The systems management software documentation describes the features, requirements, installation, and basic operation of the systems management software. See the software's online help for information about the alert messages issued by the software.
- 1 Operating system documentation is included if you ordered the software with the system. This documentation describes how to install (if necessary), configure, and use the operating system software.
- 1 Documentation is included with any options you purchased separately from the system. This documentation includes information that you need to configure and install these options in your system.

You may also have the following documents:

- 1 Documentation updates are sometimes included with the system to describe changes to the system or software.  
  
 **NOTE:** Always read these updates before consulting any other documentation because the updates often contain information that supersedes the information in the other documents.
  - 1 Technical information files—sometimes called "readme" files—may be installed on the hard drive to provide last-minute updates about technical changes to the system or advanced technical reference material intended for experienced users or technicians.
- 

## Obtaining Technical Assistance

If at any time you do not understand a procedure described in this guide or if your system does not perform as expected, a number of tools are provided to help you. For more information on these help tools, see "[Getting Help](#)."

---

[Back to Contents Page](#)

## Indicators, Messages, and Codes

### Dell™ PowerEdge™ 6600 Systems Installation and Troubleshooting Guide

- [System Status Indicators](#)
- [Front-Panel Indicators and Features](#)
- [Back-Panel Indicators and Features](#)
- [SCSI Hard-Drive Indicator Codes](#)
- [Power-Supply Indicator Codes](#)
- [NIC Indicator Codes](#)
- [Expansion-Slot Indicator Codes](#)
- [LCD Status Messages](#)
- [System Messages](#)
- [System Beep Codes](#)
- [Warning Messages](#)
- [Diagnostics Messages](#)
- [Alert Messages](#)

Applications, operating systems, and the system itself are capable of identifying problems and alerting you to them. When a problem occurs, a message may appear on the monitor or front-panel status LCD, or a beep code may sound.

Several different types of messages can indicate when the system is not functioning properly:

- 1 System status indicators
- 1 Front-panel indicators and features
- 1 Back-panel indicators and features
- 1 SCSI hard-drive indicator codes
- 1 Power-supply indicator codes
- 1 NIC indicator codes
- 1 Expansion-slot indicator codes
- 1 LCD status messages
- 1 System messages
- 1 System beep codes
- 1 Warning messages
- 1 Diagnostics messages
- 1 Alert messages

The system indicators and features are illustrated in [Figure 2-1](#) through [Figure 2-7](#). This section also describes each type of message and lists the possible causes and actions you can take to resolve any problems indicated by a message. To determine what type of message you have received, read the following subsections.

## System Status Indicators

The system's bezel has an indicator that can represent system status when the bezel is installed (see [Figure 2-1](#)). The indicator identifies when the system is operating properly or when the system needs attention. The back-panel system status indicator functions the same as the bezel's status indicator. A caution code identifies a problem with power supply, system or power-supply fans, system temperature, hard drives, or expansion cards.

[Table 2-1](#) lists the system's status indicator codes.

**Figure 2-1. System Status Indicators**

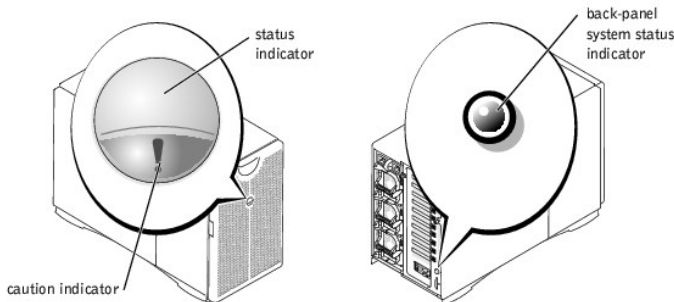

**Table 2-1. System Status Indicator Codes**

Bezel Indicators	Back-Panel	Indicator Code
------------------	------------	----------------



Status	Caution	Indicator	
Off	Off	Off	No power is available to the system, or the system is not powered on.
On	Off	Blue	The system is operating normally.
Off	Blinking	Amber blinking	The system has detected an error and requires attention.
Blinking	Off	Blue blinking	The system is identifying itself.
<p><b>NOTE:</b> Systems management software causes the status indicator to blink to identify a particular system. For more information, see the systems management software documentation.</p>			

## Front-Panel Indicators and Features

Additional indicators are located behind the bezel for system power and hard drives. The CD and diskette drives have green activity indicators. The front-panel LCD provides status information using an alphanumeric character display (see "[LCD Status Messages](#)"). See [Figure 2-2](#) for the front-panel indicators and features.

Figure 2-2. Front-Panel Features

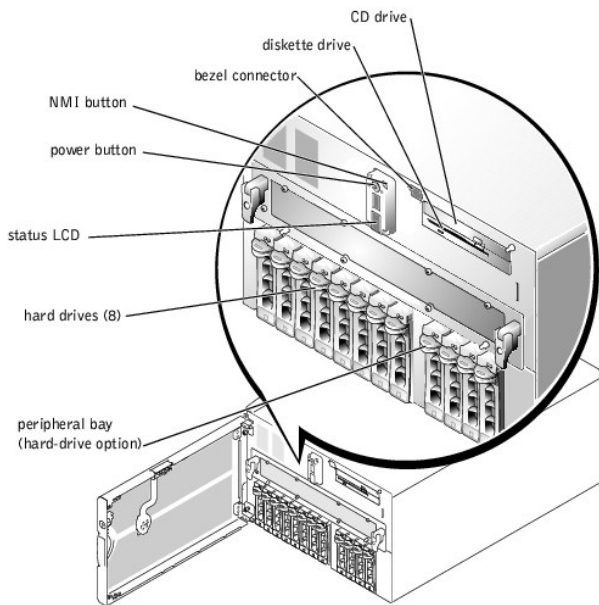

## Back-Panel Indicators and Features

[Figure 2-3](#) shows the back-panel features of the system.

Figure 2-3. Back-Panel Features

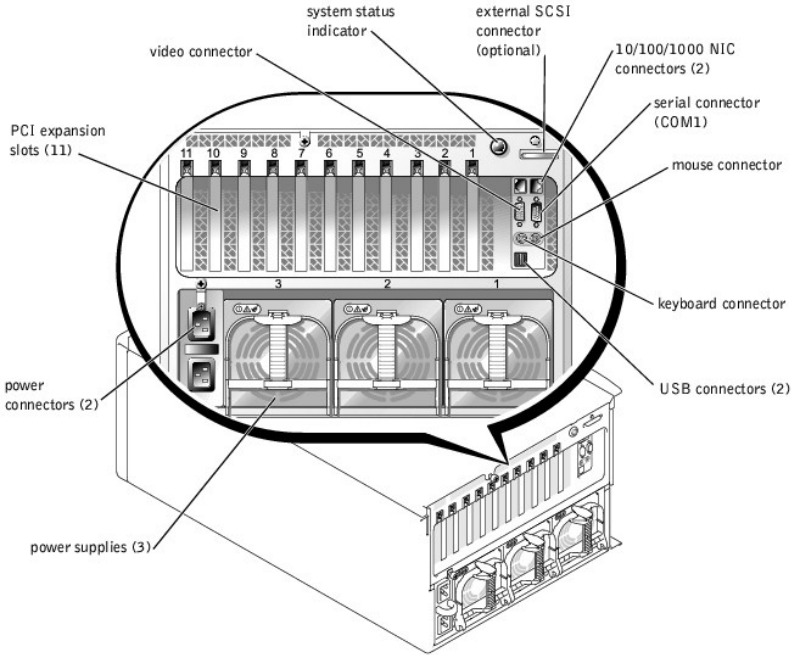

## SCSI Hard-Drive Indicator Codes

Each SCSI hard-drive carrier has two indicators: a busy indicator and a status indicator (see [Figure 2-4](#)). The indicators provide information on the status of the respective hard drive. [Table 2-2](#) lists the drive indicator codes.

Figure 2-4. SCSI Hard-Drive Indicators

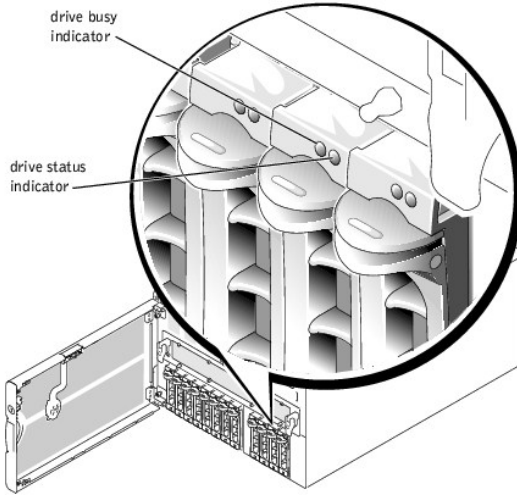

[Table 2-2](#) lists the drive indicator codes. Different codes display as drive events occur in the system. For example, in the event of a hard-drive failure, the "drive fail" code appears. After the drive is selected for removal, the "prepared for removal" code appears. After the replacement drive is installed, the "Prepare for operation, drive online" code appears.

Table 2-2. SCSI Hard-Drive Indicator Codes

Indicator	Indicator Code
Off	Drive bay empty, ready for insertion or removal
Steady green	Drive being prepared for operation, drive online
Blinks green four times per second	Identify drive

Blinks green twice per second at equal intervals	Drive being prepared for removal
Blinks green twice per second at unequal intervals	Drive rebuilding
Blinks amber four times per second	Drive failed
Blinks green, then amber, and then off, repeating this sequence every two seconds	Predicted failure for the drive
Steady green	Drive online

**NOTE:** The drive busy indicator identifies whether the hard drive is active on the SCSI bus. This indicator is controlled by the hard drive.

## Power-Supply Indicator Codes

Each hot-pluggable power supply has three indicators that can provide information on power status, fault, and the presence of AC power (see [Figure 2-5](#)). [Table 2-3](#) lists the power-supply indicator codes.

Figure 2-5. Power-Supply Indicators

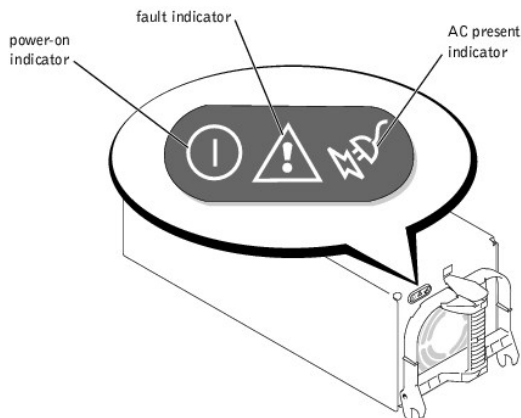

Table 2-3. Power-Supply Indicator Codes

Indicator	Indicator Code
Power-on	Green indicates that the power supply is operational.
Fault	Red indicates a problem with the power supply (fan failure, voltage error, etc.).
AC present	Green indicates that AC power is present at the power supply and that the system is connected to an AC source.

## NIC Indicator Codes

Each NIC has an indicator that provides information on network activity and link status (see [Figure 2-6](#)). [Table 2-4](#) lists the NIC indicator codes.

Figure 2-6. NIC Indicators

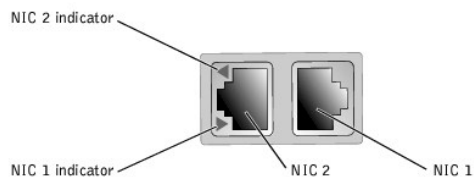

Table 2-4. NIC Indicator Codes

Indicator	Indicator Code
Off	The NIC is not connected to the network.
Green	The NIC is connected to a valid link partner.
Amber blinking	Network data is being sent or received.

## Expansion-Slot Indicator Codes

An indicator is located beside each PCI hot-pluggable expansion slot (see [Figure 2-7](#)). The indicators show through the back-panel vents. [Table 2-5](#) lists the codes for these indicators.

Figure 2-7. Expansion-Slot Indicators

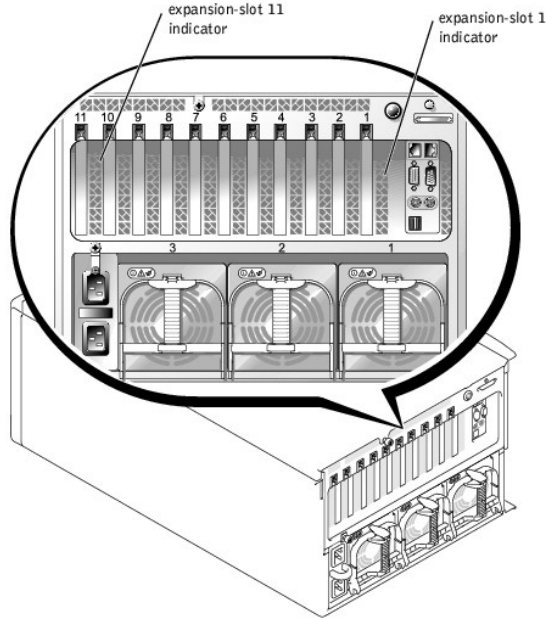

Table 2-5. Expansion-Slot Indicator Code

Indicator	Indicator Code
Off	Expansion-slot power is off. No action is required.
Green	Expansion-slot power is on. No action is required.
Green blinking fast	Expansion slot is being identified by an application program or driver. No action is required.
Amber blinking slow	Expansion card is faulty or improperly installed, causing a problem with power supply to the card.
Amber blinks twice, pauses, and then repeats the sequence	Expansion card of a slower operating speed was hot-plugged. If you are replacing an expansion card with a card of a slower operating speed, you must power down the system to install the replacement card.

## LCD Status Messages

The system's bezel indicator can signify when the system is operating correctly or when the system needs attention (see [Figure 2-1](#)). When the bezel indicator signifies an error condition, open the bezel to see further information provided by the LCD.

The LCD can display two lines of alphanumeric characters. The display codes are presented in two color combinations:

- 1 White characters on a blue background — Information only; no action is required.
- 1 Amber characters on a black background — The system needs attention.

[Table 2-6](#) lists the LCD status messages that can occur and the probable cause for each message. The LCD messages refer to events recorded in the system event log (SEL). For information on the SEL and configuring system management settings, see the systems management software documentation found on the documentation CD that shipped with your system.

 **NOTE:** Before you perform any procedures described in [Table 2-6](#), see "[Before You Begin](#)" in "Troubleshooting Your System."

Table 2-6. LCD Status Messages

Line 1 Message	Line 2 Message	Causes	Corrective Actions
----------------	----------------	--------	--------------------

SYSTEM ID	SYSTEM NAME	<p>SYSTEM ID is a unique name, 5 characters or less, defined by the user.</p> <p>SYSTEM NAME is a unique name, 16 characters or less, defined by the user.</p> <p>The system ID and name display under the following conditions:</p> <ul style="list-style-type: none"> <li>1 When the system is powered on</li> <li>1 When power is off and active POST errors are displayed</li> </ul>	<p>This message is for information only.</p> <p>You can change the system ID and name in the System Setup program. See your system's <i>User's Guide</i>.</p>
E0000	OVRFLW CHECK LOG	<p>LCD overflow message.</p> <p>A maximum of three error messages can display sequentially on the LCD. The fourth message displays as the standard overflow message.</p>	Check the SEL for details on the events.
E0119	DRAC TEMP	Remote access card is out of acceptable temperature range.	See " <a href="#">Troubleshooting System Cooling</a> " in "Troubleshooting Your System."
E0119	TEMP AMBIENT	Ambient system temperature is out of acceptable range.	
E0119	TEMP BP	Backplane board is out of acceptable temperature range.	See " <a href="#">Troubleshooting System Cooling</a> " in "Troubleshooting Your System." Ensure that all power supply fans are operating properly. See " <a href="#">Troubleshooting Power Supplies</a> " in "Troubleshooting Your System."
E0119	TEMP CPU n	Specified microprocessor is out of acceptable temperature range.	See " <a href="#">Troubleshooting System Cooling</a> " in "Troubleshooting Your System." If the problem persists, ensure that the specified microprocessor heat sink(s) are properly installed (see " <a href="#">Adding or Replacing a Microprocessor</a> " in "Installing System Options").
E0119	TEMP MEM n	Specified memory riser card is out of acceptable temperature range.	See " <a href="#">Troubleshooting System Cooling</a> " in "Troubleshooting Your System."
E0119	TEMP PBAY	Peripheral bay is out of acceptable temperature range.	Ensure that all power supply fans are operating properly. See " <a href="#">Troubleshooting Power Supplies</a> " in "Troubleshooting Your System."
E0119	TEMP SYSTEM	I/O riser card or I/O board is out of acceptable temperature range.	See " <a href="#">Troubleshooting System Cooling</a> " in "Troubleshooting Your System."
E0212	DRAC EXT POWER	Remote access card is out of acceptable voltage range; faulty or improperly installed power supply or remote access card.	See " <a href="#">Troubleshooting Power Supplies</a> " in "Troubleshooting Your System." If the problem persists, ensure that the remote access card is properly installed. If the problem persists, replace the remote access card (see " <a href="#">Removing an Expansion Card</a> " in "Installing System Options").
E0212	DRAC VOLT BATT		
E0212	DRAC VOLT PCI		
E0212	VOLT 3.3	System power supply is out of acceptable voltage range; faulty or improperly installed power supply.	See " <a href="#">Troubleshooting Power Supplies</a> " in "Troubleshooting Your System."
E0212	VOLT 5		
E0212	VOLT 12		
E0212	VOLT BATT	Faulty battery or I/O riser card.	See " <a href="#">Troubleshooting the System Battery</a> " and " <a href="#">Troubleshooting the I/O Riser Card</a> " in "Troubleshooting Your System."
E0212	VOLT BP 12	Backplane board is out of acceptable voltage range.	Ensure that the power cables are securely connected to the backplane board (see " <a href="#">Installing Drives</a> "). If the problem persists, see " <a href="#">Troubleshooting Power Supplies</a> " in "Troubleshooting Your System."
E0212	VOLT BP 3.3		
E0212	VOLT BP 5		
E0212	VOLT CPU VRM	Microprocessor VRM voltage is out of acceptable range; faulty or improperly installed microprocessor VRM; faulty microprocessor board.	Ensure that supported VRMs of the same type are properly installed. If the problem persists, replace the VRM (see " <a href="#">Adding or Replacing a Microprocessor</a> " in "Installing System Options"). If the problem persists, replace the microprocessor board (see " <a href="#">Getting Help</a> ").
E0212	VOLT NIC 1.8V	Integrated NIC voltage is out of acceptable range; faulty or improperly installed I/O riser card; faulty or improperly installed power supply.	See " <a href="#">Troubleshooting the I/O Board</a> " and " <a href="#">Troubleshooting Power Supplies</a> " in "Troubleshooting Your System."
E0212	VOLT NIC 2.5V		
E0212	VOLT MEMORY n	Specified memory riser card is out of acceptable voltage range; faulty or improperly installed memory card; faulty or improperly installed power supply.	Ensure that the memory riser card is properly installed. If the problem persists, replace the memory riser card (see " <a href="#">Removing the Memory Riser Cards</a> " in "Installing System Options"). If the problem persists, see " <a href="#">Troubleshooting Power Supplies</a> " in "Troubleshooting Your System."
E0212	VOLT PBAY 12	Peripheral bay is out of acceptable voltage range.	Ensure that the power cables are securely connected to the peripheral bay backplane board (see " <a href="#">Installing Drives</a> "). If the problem persists, see " <a href="#">Troubleshooting Power Supplies</a> " in "Troubleshooting Your System."
E0212	VOLT PBAY 3.3		
E0212	VOLT PBAY 5		
E0212	VOLT PLANAR REG	Microprocessor board is out of acceptable voltage range; faulty or improperly installed microprocessor board.	See " <a href="#">Troubleshooting the Microprocessor Board</a> " in "Troubleshooting Your System."
E0276	CPU VRM n	Specified microprocessor VRM is faulty, unsupported, or improperly installed.	Ensure that supported VRMs of the same type are properly installed. If the problem persists, replace the VRM (see " <a href="#">Adding or Replacing a Microprocessor</a> " in "Installing System Options").
E0276	MISMATCH VRM n		
E0280	MISSING VRM n	Specified microprocessor VRM is improperly installed or missing.	Ensure that a supported VRM is properly installed for each microprocessor. If the problem persists, replace the VRM (see " <a href="#">Adding or Replacing a Microprocessor</a> " in "Installing System Options").
E0319	PCI OVER CURRENT	Faulty or improperly installed expansion card or I/O board.	See " <a href="#">Troubleshooting the I/O Board</a> " and " <a href="#">Troubleshooting Expansion Cards</a> " in "Troubleshooting Your System."
E0412	RPM FAN n	Specified cooling fan is faulty, improperly installed, or missing	See " <a href="#">Troubleshooting a Cooling Fan</a> " in "Troubleshooting Your System."

E0780	MISSING CPU 1	Microprocessor is not installed in socket 1.	Install a microprocessor in socket 1 (see <a href="#">"Adding or Replacing a Microprocessor"</a> in "Installing System Options"). To identify microprocessor socket 1, see <a href="#">Figure A-4</a> .
E07F0	CPU IERR	Faulty or improperly installed microprocessor, microprocessor board, or I/O board.	See <a href="#">"Troubleshooting the Microprocessor Board"</a> and <a href="#">"Troubleshooting the I/O Board"</a> in "Troubleshooting Your System."
E07F1	TEMP CPU n HOT	Specified microprocessor is out of acceptable temperature range and has halted operation.	See <a href="#">"Troubleshooting System Cooling"</a> in "Troubleshooting Your System." If the problem persists, ensure that the microprocessor heat sinks are properly installed (see <a href="#">"Adding or Replacing a Microprocessor"</a> in "Installing System Options").
E07F4	POST CACHE	Faulty or improperly installed microprocessor or microprocessor board.	See <a href="#">"Troubleshooting the Microprocessor Board"</a> in "Troubleshooting Your System."
E07F4	POST CPU REG		
E07F4	POST CPU SMI	SMI handler failed to initialize: faulty or improperly installed I/O riser card, I/O board, or microprocessor board.	See <a href="#">"Troubleshooting the I/O Riser Card," "Troubleshooting the I/O Board,"</a> and <a href="#">"Troubleshooting the Microprocessor Board"</a> in "Troubleshooting Your System."
E07FA	TEMP CPU n THERM	Specified microprocessor is out of acceptable temperature range and is operating at a reduced speed, or frequency.	See <a href="#">"Troubleshooting System Cooling"</a> in "Troubleshooting Your System." If the problem persists, ensure that the microprocessor heat sinks are properly installed (see <a href="#">"Adding or Replacing a Microprocessor"</a> in "Installing System Options").
E0876	POWER PS n	No power is available from the specified power supply; specified power supply is improperly installed or faulty.	See <a href="#">"Troubleshooting Power Supplies"</a> in "Troubleshooting Your System."
E0880	INSUFFICIENT POWER PS	Insufficient power is being supplied to the system; power supplies are improperly installed, faulty, or missing.	See <a href="#">"Troubleshooting Power Supplies"</a> in "Troubleshooting Your System."
E08F4	AC LINE n	No power available through the specified power cord.	Ensure that all power cords are securely connected. See <a href="#">"External Connections"</a> in "Troubleshooting Your System."
E0CB2	MEM MIRROR	Uncorrectable memory error was remapped to the mirrored memory bank.	See <a href="#">"Troubleshooting System Memory"</a> in "Troubleshooting Your System."
E0CB2	MEM SPARE ROW	Correctable errors threshold was met in a memory bank, and errors are remapped to the spare row.	
E0CF1	MBE DIMM Bank n	Memory modules installed in the specified bank are not the same type and size; faulty memory module(s).	Ensure that all banks contain memory modules of the same type and size and that they are properly installed. If the problem persists, see <a href="#">"Troubleshooting System Memory"</a> in "Troubleshooting Your System."
E0CF1	POST MEM 64K	Parity failure in the first 64 KB of main memory.	See <a href="#">"Troubleshooting System Memory"</a> in "Troubleshooting Your System."
E0CF1	POST NO MEMORY	Main-memory refresh verification failure.	Ensure that all banks contain memory modules of the same type and size and that they are properly installed. If the problem persists, see <a href="#">"Troubleshooting System Memory"</a> in "Troubleshooting Your System."
E0CF5	LOG DISABLE SBE	Multiple single-bit errors on a single memory module.	See <a href="#">"Troubleshooting System Memory"</a> in "Troubleshooting Your System."
E0D76	DRIVE FAIL	Faulty or improperly installed hard drive or RAID controller.	See <a href="#">"Troubleshooting Hard Drives"</a> and <a href="#">"Troubleshooting a RAID Controller Card"</a> in "Troubleshooting Your System."
E0F04	POST CMOS	CMOS write/read failure: faulty or improperly installed I/O riser card, I/O board, or microprocessor board.	See <a href="#">"Troubleshooting the I/O Riser Card," "Troubleshooting the I/O Board,"</a> and <a href="#">"Troubleshooting the Microprocessor Board"</a> in "Troubleshooting Your System."
E0F04	POST CPU SPEED	Microprocessor speed control sequence failure.	See <a href="#">"Troubleshooting the Microprocessor Board"</a> in "Troubleshooting Your System."
E0F04	POST DMA INIT	DMA initialization failure; DMA page register write/read failure.	See <a href="#">"Troubleshooting System Memory"</a> and <a href="#">"Troubleshooting the I/O Board"</a> in "Troubleshooting Your System."
E0F04	POST DMA REG	Faulty I/O board.	See <a href="#">"Troubleshooting the I/O Board"</a> in "Troubleshooting Your System."
E0F04	POST KYB CNTRL	Faulty keyboard controller; faulty I/O riser card.	See <a href="#">"Troubleshooting the I/O Riser Card"</a> in "Troubleshooting Your System."
E0F04	POST MEM RFSH	Main-memory refresh verification failure.	See <a href="#">"Troubleshooting System Memory"</a> in "Troubleshooting Your System."
E0F04	POST PIC REG	Master or slave PIC register test failure.	See <a href="#">"Troubleshooting the I/O Board"</a> in "Troubleshooting Your System."
E0F04	POST SHADOW	BIOS shadowing failure.	See <a href="#">"Troubleshooting the I/O Board"</a> and <a href="#">"Troubleshooting System Memory"</a> in "Troubleshooting Your System."
E0F04	POST SHD TEST	Shutdown test failure.	
E0F04	POST SIO	Super I/O chip failure; faulty I/O riser card.	See <a href="#">"Troubleshooting the I/O Riser Card"</a> in "Troubleshooting Your System."
E0F04	POST TIMER	Programmable interval timer test failure; faulty I/O board.	See <a href="#">"Troubleshooting the I/O Board"</a> in "Troubleshooting Your System."
E0F0B	POST ROM CHKSUM	Faulty or improperly installed expansion card.	See <a href="#">"Troubleshooting Expansion Cards"</a> in "Troubleshooting Your System."
E0F0C	VID MATCH CPU n	Specified microprocessor is faulty, unsupported, improperly installed, or missing.	See <a href="#">"Troubleshooting the Microprocessor Board"</a> in "Troubleshooting Your System."
E10F3	LOG DISABLE BIOS	BIOS disabled logging errors.	Check the SEL for details on the errors.
E13F2	IO CHANNEL CHECK	Faulty or improperly installed expansion card or I/O board.	See <a href="#">"Troubleshooting Expansion Cards"</a> and <a href="#">"Troubleshooting the I/O Board"</a> in "Troubleshooting Your System."
E13F4	PCI PARITY		
E13F5	PCI SYSTEM		
E13F8	CPU BUS INIT	Faulty or improperly installed microprocessor, microprocessor board, or I/O board.	See <a href="#">"Troubleshooting the I/O Board"</a> and <a href="#">"Troubleshooting the Microprocessor Board"</a> in "Troubleshooting Your System."
E13F8	CPU BUS PARITY	Faulty microprocessor board.	See <a href="#">"Troubleshooting the Microprocessor Board"</a> in "Troubleshooting Your System."
E13F8	CPU MCKERR	Machine check error; faulty or improperly installed microprocessor or microprocessor	

		board.	
E13F8	HOST BUS	Faulty or improperly installed I/O board or microprocessor board.	See " <a href="#">Troubleshooting the I/O Board</a> " and " <a href="#">Troubleshooting the Microprocessor Board</a> " in "Troubleshooting Your System."
E13F8	HOST TO PCI BUS		
E13F8	MEM CONTROLLER	Faulty or improperly installed memory riser card or microprocessor board.	Ensure that the memory riser cards are properly installed. If the problem persists, replace the memory riser cards (see " <a href="#">Memory Riser Cards</a> " in "Installing System Options"). If the problem persists, see " <a href="#">Troubleshooting the Microprocessor Board</a> " in "Troubleshooting Your System."
E1580	MISSING MEM <i>n</i>	Specified memory riser card is faulty or improperly installed.	Ensure that the memory riser cards are properly installed. If the problem persists, replace the memory riser cards (see " <a href="#">Memory Riser Cards</a> " in "Installing System Options").
E1580	POWER CONTROL	Faulty power supply distribution board.	Replace the power supply distribution board (see " <a href="#">Getting Help</a> ").
E20F1	OS HANG	Operating system watchdog timer timed out.	Restart your system. If the problem persists, see your operating system documentation.
EFFF0	ESM ERROR	ESM firmware failure; faulty I/O riser card.	See " <a href="#">Troubleshooting the I/O Riser Card</a> " in "Troubleshooting Your System."
EFFF1	POST ERROR	BIOS error.	Update the BIOS firmware (see " <a href="#">Getting Help</a> ").
EFFF2	BP ERROR	Faulty or improperly installed backplane board; loose or improperly connected backplane board cables.	Ensure that the interface cables are securely connected to the backplane board (see " <a href="#">Installing Drives</a> "). If the problem persists, see " <a href="#">Getting Help</a> ."
EFFF3	DRAC ERROR	Faulty or improperly installed remote access card.	Ensure that the remote access card is properly installed. If the problem persists, replace the remote access card (see " <a href="#">Removing an Expansion Card</a> " in "Installing System Options").
<b>NOTE:</b> For the full name of an abbreviation or acronym used in this table, see " <a href="#">Abbreviations and Acronyms</a> ."			

## Solving Problems Described by LCD Status Messages

When a single message appears on the LCD, locate the code in [Table 2-6](#) and perform the suggested corrective action. The code on the LCD can often specify a very precise fault condition that is easily remedied. For example, if the code E0280 MISSING VRM 2 appears, you know that a microprocessor is installed in socket 2, but the VRM for that microprocessor is either improperly installed or missing.

In contrast, you might be able to determine the problem if multiple related errors occur. For example, if you receive a series of messages indicating multiple voltage faults, you might deduce that the problem is a failing power supply.

## Removing LCD Status Messages

For faults associated with sensors, such as temperature, voltage, fans, and so on, the LCD message is automatically removed when that sensor returns to a normal state. For example, if temperature for a component goes out of range, the LCD will display the fault; when the temperature returns to the acceptable range, the message is removed from the LCD display. For other faults, you must take some action to remove the message from the display:

- 1 Clear the SEL — You can perform this task remotely, but you will lose the event history for the system.
- 1 Chassis intrusion — When you remove the cover, the system assumes that you are servicing the bad component; the LCD clears when you replace the cover.
- 1 Power cycle — Turn off the system and disconnect it from the electrical outlet; wait approximately 10 seconds, and then connect the power cable and restart the system.

Any of these actions will remove fault messages and return the status indicators and LCD colors to the normal state. Messages will reappear under the following conditions:

- 1 The sensor returns to a normal state but fails again, resulting in a new SEL entry.
- 1 The system is reset and new error events are detected.
- 1 A failure is recorded from another source that maps to the same LCD message.

## System Messages

System messages appear on the console during POST to notify you of a possible problem with the system. If you are performing console redirection, system messages will appear on the console. [Table 2-7](#) lists the system messages that can occur and the probable cause and corrective action for each message.

 **NOTE:** If you receive a system message that is not listed in [Table 2-7](#), check the documentation for the application program that is running when the message appears or the operating system's documentation for an explanation of the message and recommended action.

 **NOTE:** Before you perform any procedures described in [Table 2-7](#), see "[Before You Begin](#)" in "Troubleshooting Your System."

**Table 2-7. System Messages**

Message	Causes	Corrective Actions
Address mark not found	Faulty diskette/CD drive subsystem or hard-drive subsystem; faulty peripheral riser card.	See " <a href="#">Troubleshooting the Diskette Drive</a> ," " <a href="#">Troubleshooting a CD Drive</a> ," and " <a href="#">Troubleshooting Hard Drives</a> " in "Troubleshooting Your System."
Alert! Redundant memory disabled! Memory configuration does not support redundant memory	Memory modules installed are not the same type and size in all banks; faulty memory module(s).	Ensure that all banks contain memory modules of the same type and size and that they are properly installed. If the problem persists, see " <a href="#">Troubleshooting System Memory</a> " in "Troubleshooting Your System."
Alert! Unsupported memory or incomplete		



sets in the following bank(s):		
Bank x		
Amount of available memory limited to 256 MB!	<b>OS Install Mode</b> is enabled in the System Setup program.	Disable <b>OS Install Mode</b> in the System Setup program (see "Using the System Setup program" in the <i>User's Guide</i> ).
Auxiliary device failure	Loose or improperly connected mouse or keyboard cable; faulty mouse or keyboard; faulty I/O riser card.	See " <a href="#">Troubleshooting the Mouse</a> " and " <a href="#">Troubleshooting the Keyboard</a> " in "Troubleshooting Your System."
BIOS Update Attempt Failed!	Remote BIOS update attempt failed.	Retry the BIOS update. If the problem persists, see " <a href="#">Getting Help</a> ."
Caution! NVRAM_CLR jumper is installed on system board. Please run SETUP	Incorrect configuration settings in System Setup program; NVRAM_CLR jumper is installed; faulty system battery.	Check the System Setup configuration settings (see "Using the System Setup Program" in the <i>User's Guide</i> ). Remove the NVRAM_CLR jumper (see <a href="#">Figure A-2</a> for jumper location).
CD-ROM drive not found	Improperly connected or missing CD drive.	See " <a href="#">Troubleshooting a CD Drive</a> " in "Troubleshooting Your System."
Checking embedded server management firmware	Embedded server management memory may be temporarily corrupted.	To clear the embedded server management memory, shut down the system, disconnect the power cords, wait approximately 30 seconds, reconnect the power cords, and then restart the system. If the problem persists, see " <a href="#">Getting Help</a> ."
CPU population error!	Faulty, improperly installed, or unsupported microprocessor.	See " <a href="#">Troubleshooting the Microprocessor Board</a> " in "Troubleshooting Your System."
CPU VRM Failure/missing/mismatch detected	Faulty, unsupported, or missing VRM (s).	Ensure that supported VRMs of the same type are properly installed. If the problem persists, replace the VRM (see " <a href="#">Adding or Replacing a Microprocessor</a> " in "Installing System Options").
CPUs with different level-3 cache sizes detected	Microprocessors with different level 3 (L3) cache sizes are installed.	Ensure that all microprocessors have the same cache size and that they are properly installed (see " <a href="#">Adding or Replacing a Microprocessor</a> " in "Installing System Options").
Data error	Faulty diskette, diskette drive, or hard drive.	See " <a href="#">Troubleshooting the Diskette Drive</a> ," " <a href="#">Troubleshooting a CD Drive</a> ," and " <a href="#">Troubleshooting Hard Drives</a> " in "Troubleshooting Your System."
Decreasing available memory	Faulty or improperly installed memory modules.	See " <a href="#">Troubleshooting System Memory</a> " in "Troubleshooting Your System."
Diskette drive n seek failure	Incorrect configuration settings in System Setup program. Faulty or improperly installed diskette drive, or loose diskette/CD interface cable.	Run the System Setup program to correct the settings (see "Using the System Setup Program" in the <i>User's Guide</i> ). See " <a href="#">Troubleshooting the Diskette Drive</a> " in "Troubleshooting Your System."
Diskette read failure	Faulty or improperly inserted diskette.	Replace the diskette.
Diskette subsystem reset failed	Faulty diskette/CD drive controller; faulty peripheral riser card.	See " <a href="#">Troubleshooting the Diskette Drive</a> " in "Troubleshooting Your System."
Diskette write protected	Diskette write-protect feature enabled.	Move the write-protect tab on the diskette to disable the write-protect feature.
Drive not ready	Faulty or improperly inserted diskette.	Insert the diskette properly in the diskette drive, or replace the diskette.
Embedded server management error	Embedded server management memory may be temporarily corrupted.	To clear the embedded server management memory, shut down the system, disconnect the power cords, wait approximately 30 seconds, reconnect the power cords, and then restart the system. If the problem persists, see " <a href="#">Getting Help</a> ."
Embedded server management is not present		
Error: DRAC III initialization failure	Faulty remote access card or I/O board.	Ensure that the remote access card is properly installed. If the problem persists, replace the remote access card (see " <a href="#">Installing an Expansion Card</a> " in "Installing System Options").
Error: DRAC III cannot be used with an add-in video card, system halted	The system supports only the embedded video when using a remote access card.	Remove the add-in video expansion card (see " <a href="#">Removing an Expansion Card</a> " in "Installing System Options").
Error: DRAC III is not in the correct PCI slot, system halted	The remote access card is not in PCI slot 1.	Install the remote access card in PCI slot 1 (see " <a href="#">Installing an Expansion Card</a> " in "Installing System Options").
Error: More than one DRAC III detected, system halted	The system supports only one remote access card.	Remove the remote access card(s) not in PCI slot 1 (see " <a href="#">Removing an Expansion Card</a> " in "Installing System Options").
Extended Security Enabled!	Extended Security is enabled in the System Setup program.	See "Using the System Setup Program" in the <i>User's Guide</i> .
Failed to copy memory Banks 1 & 2 to Banks 3 & 4 in Mirror mode	Faulty or improperly installed memory modules.	See " <a href="#">Troubleshooting System Memory</a> " in "Troubleshooting Your System."
Gate A20 failure	Faulty keyboard controller; faulty I/O riser card.	See " <a href="#">Troubleshooting the I/O Riser Card</a> " in "Troubleshooting Your System."
General failure	Operating system corrupted or not installed properly.	Reinstall the operating system.
I/O card parity interrupt at address	Faulty or improperly installed expansion card.	See " <a href="#">Troubleshooting Expansion Cards</a> " in "Troubleshooting Your System."
IMB bus error	Faulty or improperly installed I/O board or microprocessor board.	See " <a href="#">Troubleshooting the I/O Board</a> " and " <a href="#">Troubleshooting the Microprocessor Board</a> " in "Troubleshooting Your System."
Insufficient number of power supplies detected, system halted.	Insufficient power is being supplied to the system; specified power supply is improperly installed, faulty, or missing.	See " <a href="#">Troubleshooting Power Supplies</a> " in "Troubleshooting Your System."
Invalid configuration information - please run SETUP program	Incorrect configuration settings in System Setup program; NVRAM_CLR jumper is installed; faulty system battery.	Check the System Setup configuration settings (see "Using the System Setup Program" in the <i>User's Guide</i> ). Remove the NVRAM_CLR jumper (see <a href="#">Figure A-2</a> for jumper location). If the problem persists, see " <a href="#">Troubleshooting the System Battery</a> " in "Troubleshooting Your System."



Invalid ESCD Configuration, Resources Reallocated	System configuration data has been ignored.	Check the System Setup configuration settings (see "Using the System Setup Program" in the <i>User's Guide</i> ).
Invalid SCSI Configuration; Daughter Card Detected, SCSI cable not present on connector A of the primary backplane.	SCSI cable is loose, improperly connected, or faulty.	Check the SCSI cable connection. If the problem persists, add or replace the SCSI cable (see <a href="#">"Getting Help"</a> ).
Invalid SCSI Configuration; Daughter Card Detected, SCSI cable not present on connector B of the primary backplane.		
Invalid SCSI Configuration; Daughter Card Not Detected, SCSI cable present on connector B of the primary backplane.	SCSI channel B cable present; backplane daughter card is not installed.	Install the SCSI backplane daughter card (see <a href="#">"Getting Help"</a> ).
Invalid SCSI Configuration; SCSI cable not present on connector A of the primary backplane	SCSI cable is loose, improperly connected, or faulty.	Check the SCSI cable connection. If the problem persists, add or replace the SCSI cable (see <a href="#">"Getting Help"</a> ).
Keyboard controller failure	Faulty keyboard controller; faulty I/O riser card.	See <a href="#">"Troubleshooting the I/O Riser Card"</a> in "Troubleshooting Your System."
Keyboard data line failure	Loose or improperly connected keyboard cable; dirty or faulty keyboard; faulty keyboard controller; faulty I/O riser card.	See <a href="#">"Troubleshooting the Keyboard"</a> and <a href="#">"Troubleshooting the I/O Riser Card"</a> in "Troubleshooting Your System."
Keyboard failure		
Keyboard stuck key failure		
Memory address line failure at <i>address</i> , read value expecting value	Faulty or improperly installed memory modules; faulty microprocessor board.	See <a href="#">"Troubleshooting System Memory"</a> in "Troubleshooting Your System."
Memory double word logic failure at <i>address</i> , read value expecting value		
Memory high address line failure at <i>start address</i> to <i>end address</i>		
Memory high data line failure at <i>start address</i> to <i>end address</i>		
Memory odd/even logic failure at <i>start address</i> to <i>end address</i>		
Memory write/read failure at <i>address</i> , read value expecting value		
Memory allocation error	Faulty application program.	Restart the application program.
Memory bank population error!	Memory modules installed are not the same type and size in each bank; faulty memory module(s); memory modules are not installed sequentially.	Ensure that all banks contain memory modules of the same type and size and that they are properly installed. Ensure that banks are populated sequentially (see <a href="#">"Memory Module Installation Guidelines"</a> in "Installing System Options"). If the problem persists, see <a href="#">"Troubleshooting System Memory"</a> in "Troubleshooting Your System."
Memory parity failure at <i>start address</i> to <i>end address</i>	Faulty or improperly installed memory modules.	See <a href="#">"Troubleshooting System Memory"</a> in "Troubleshooting Your System."
Memory parity error at <i>address</i>		
Memory parity interrupt at <i>address</i>		
Memory tests terminated by keystroke	POST memory test terminated by pressing the spacebar.	No action is required.
No boot device available	Faulty or missing CD/diskette drive subsystem, hard drive, or hard-drive subsystem.	See <a href="#">"Troubleshooting the Diskette Drive,"</a> <a href="#">"Troubleshooting a CD Drive,"</a> and <a href="#">"Troubleshooting Hard Drives"</a> in "Troubleshooting Your System."
No boot sector on hard-disk	No operating system on hard drive.	Check the hard-drive configuration settings in the System Setup program (see "Using the System Setup Program" in the <i>User's Guide</i> ).
No microcode update loaded for Processor <i>n</i>	BIOS error.	Update the BIOS firmware (see <a href="#">"Getting Help"</a> ).
No timer tick interrupt	Faulty I/O board.	See <a href="#">"Troubleshooting the I/O Board"</a> in "Troubleshooting Your System."
Non-system disk or disk error	Faulty diskette, diskette/CD drive assembly, hard drive, or hard-drive subsystem; no operating system on diskette or hard drive.	Use a bootable diskette. If the problem persists, see <a href="#">"Troubleshooting the Diskette Drive,"</a> <a href="#">"Troubleshooting a CD Drive,"</a> and <a href="#">"Troubleshooting Hard Drives"</a> in "Troubleshooting Your System."
Not a boot diskette	No operating system on diskette.	Use a bootable diskette.
PCI BIOS failed to install	Loose cables to expansion card(s); faulty or improperly installed expansion card.	Ensure that all appropriate cables are securely connected to the expansion cards. If the problem persists, see <a href="#">"Troubleshooting Expansion Cards"</a> in "Troubleshooting Your System."
PCI bus error	Faulty or improperly installed expansion card; faulty I/O board.	See <a href="#">"Troubleshooting Expansion Cards"</a> in "Troubleshooting Your System."
Plug & Play Configuration Error Embedded <i>xxx</i>	Error encountered in initializing PCI device; faulty I/O board.	Install the NVRAM_CLR jumper and reboot the system. If the problem persists, see <a href="#">"Troubleshooting Expansion Cards"</a> in "Troubleshooting Your System."
Plug & Play Configuration Error PCI Slot <i>n</i>	Error encountered in initializing PCI adapter.	
Primary backplane is not present	SCSI cable is loose, improperly connected, or faulty.	Check the SCSI cable connection. If the problem persists, add or replace the SCSI cable (see <a href="#">"Getting Help"</a> ).
Processor VID mismatching/VRM missing	Faulty, unsupported, or missing VRM	Ensure that supported VRMs of the same type are properly installed. If

or failure detected	(s).	the problem persists, replace the VRM (see " <a href="#">Adding or Replacing a Microprocessor</a> " in "Installing System Options").
Read fault	Faulty diskette, diskette/CD drive assembly, hard drive, or hard-drive subsystem; faulty peripheral riser card.	See " <a href="#">Troubleshooting the Diskette Drive</a> ," " <a href="#">Troubleshooting a CD Drive</a> ," and " <a href="#">Troubleshooting Hard Drives</a> " in "Troubleshooting Your System."
Requested sector not found		
Reset failed	Improperly connected drive interface or power cable.	Ensure that the interface cable is securely connected between the diskette/CD interposer board and the peripheral riser card. Ensure that the interface and power cables are securely connected to the backplane board (see " <a href="#">Installing Drives</a> ").
ROM bad checksum = address	Faulty or improperly installed expansion card.	See " <a href="#">Troubleshooting Expansion Cards</a> " in "Troubleshooting Your System."
Secondary backplane is not present	SCSI cable is loose, improperly connected, or faulty.	Check the SCSI cable connection. If the problem persists, add or replace the SCSI cable (see " <a href="#">Getting Help</a> ").
Sector not found	Faulty diskette, diskette/CD drive assembly, or hard drive.	See " <a href="#">Troubleshooting the Diskette Drive</a> ," " <a href="#">Troubleshooting a CD Drive</a> ," and " <a href="#">Troubleshooting Hard Drives</a> " in "Troubleshooting Your System."
Seek error		
Seek operation failed		
Shutdown failure	Shutdown test failure.	See " <a href="#">Troubleshooting System Memory</a> " and " <a href="#">Troubleshooting the I/O Board</a> " in "Troubleshooting Your System."
System halted! Must power down	Wrong password entered too many times.	Informational only.
Time-of-day clock stopped	Faulty battery or I/O riser card.	See " <a href="#">Troubleshooting the System Battery</a> " and " <a href="#">Troubleshooting the I/O Riser Card</a> " in "Troubleshooting Your System."
Time-of-day not set - please run SETUP program	Incorrect <b>Time</b> or <b>Date</b> settings; faulty system battery.	Check the <b>Time</b> and <b>Date</b> settings (see "Using the System Setup Program" in the <i>User's Guide</i> ). If the problem persists, replace the system battery (see " <a href="#">System Battery</a> " in "Installing System Options").
Timer chip counter 2 failed	Faulty I/O board.	See " <a href="#">Troubleshooting the I/O Board</a> " in "Troubleshooting Your System."
Unable to access processor PROM	Faulty or improperly installed microprocessor; faulty microprocessor board.	See " <a href="#">Troubleshooting the Microprocessor Board</a> " in "Troubleshooting Your System."
Unexpected interrupt in protected mode	Improperly installed memory modules or faulty keyboard/mouse controller; faulty I/O riser card.	See " <a href="#">Troubleshooting System Memory</a> " and " <a href="#">Troubleshooting the I/O Riser Card</a> " in "Troubleshooting Your System."
Unsupported CPU combination	Microprocessor(s) is not supported by the system.	Install a supported microprocessor combination (see " <a href="#">Microprocessors</a> " in "Installing System Options").
Unsupported CPU stepping detected		
Utility partition not available	<F10> key was pressed during POST, but no utility partition exists on the boot hard drive.	Create a utility partition on the boot hard drive (see "Using the Dell OpenManage Server Assistant CD" in your <i>User's Guide</i> ).
Verify that mouse and keyboard are securely attached to correct connectors.	Loose or improperly connected mouse or keyboard cable; faulty mouse or keyboard.	See " <a href="#">Troubleshooting the Mouse</a> " and " <a href="#">Troubleshooting the Keyboard</a> " in "Troubleshooting Your System."
Warning: Firmware is out-of-date, please update.	I/O riser card firmware error.	Update the I/O riser card firmware (see " <a href="#">Getting Help</a> ").
Warning! SCSI cable not present on connector A or connector B of the primary backplane.	SCSI cables are loose, improperly connected, or faulty.	Check the SCSI cable connections. If problem persists, add or replace the SCSI cables (see " <a href="#">Getting Help</a> ").
Write fault	Faulty diskette, diskette/CD drive assembly, hard drive, or hard-drive subsystem.	See " <a href="#">Troubleshooting the Diskette Drive</a> ," " <a href="#">Troubleshooting a CD Drive</a> ," and " <a href="#">Troubleshooting Hard Drives</a> " in "Troubleshooting Your System."
Write fault on selected drive		

**NOTE:** For the full name of an abbreviation or acronym used in this table, see "[Abbreviations and Acronyms](#)."

## System Beep Codes

When an error that cannot be reported on the monitor occurs during a boot routine, the system may emit a series of beeps that identify the problem.

When a beep code is emitted, record it on a copy of the Diagnostics Checklist in "[Getting Help](#)," and then look it up in [Table 2-8](#). If you are unable to resolve the problem by looking up the meaning of the beep code, use system diagnostics to identify a more serious cause. If you are still unable to resolve the problem, see "[Getting Help](#)."

 **NOTE:** If the system boots without a keyboard, mouse, or monitor attached, the system will not issue beep codes related to those peripherals.

 **NOTE:** Before you perform any procedures described in [Table 2-8](#), see "[Before You Begin](#)" in "Troubleshooting Your System."

**Table 2-8. System Beep Codes**

Code	Cause	Corrective Action
1-1-2	CPU register test failure	See " <a href="#">Troubleshooting the Microprocessor Board</a> " in "Troubleshooting Your System."
1-1-3	CMOS write/read failure; faulty or improperly installed I/O riser card, I/O board, or microprocessor board	See " <a href="#">Troubleshooting the I/O Riser Card</a> ," " <a href="#">Troubleshooting the I/O Board</a> ," and " <a href="#">Troubleshooting the Microprocessor Board</a> " in "Troubleshooting Your System."
1-1-4	BIOS error	Refresh the BIOS firmware (see " <a href="#">Getting Help</a> ").
1-2-1	Programmable interval-timer failure; faulty I/O board	See " <a href="#">Troubleshooting the I/O Board</a> " in "Troubleshooting Your System."

1-2-2	DMA initialization failure	See " <a href="#">Troubleshooting System Memory</a> " and " <a href="#">Troubleshooting the I/O Board</a> " in "Troubleshooting Your System."	
1-2-3	DMA page register write/read failure		
1-3-1	Main-memory refresh verification failure		
1-3-2	No memory installed		
1-3-3	Chip or data line failure in the first 64 KB of main memory		
1-3-4	Odd/even logic failure in the first 64 KB of main memory		
1-4-1	Address line failure in the first 64 KB of main memory		
1-4-2	Parity failure in the first 64 KB of main memory		
1-4-3	Fail-safe timer test failure		
1-4-4	Software NMI port test failure		
2-1-1 through 2-4-4	Bit failure in the first 64 KB of main memory		
3-1-1	Slave DMA-register failure		See " <a href="#">Troubleshooting the I/O Board</a> " and " <a href="#">Troubleshooting the Microprocessor Board</a> " in "Troubleshooting Your System."
3-1-2	Master DMA-register failure		
3-1-3	Master interrupt-mask register failure		
3-1-4	Slave interrupt-mask register failure		
3-2-2	Interrupt vector loading failure		
3-2-4	Keyboard-controller test failure	See " <a href="#">Troubleshooting the I/O Riser Card</a> " in "Troubleshooting Your System."	
3-3-1	CMOS failure	See " <a href="#">Troubleshooting the I/O Riser Card</a> " and " <a href="#">Troubleshooting the I/O Board</a> " in "Troubleshooting Your System."	
3-3-2	System configuration check failure		
3-3-3	Keyboard controller not detected		
3-3-4	Video memory test failure		
3-4-1	Screen initialization failure		
3-4-2	Screen-retrace test failure		
3-4-3	Video ROM search failure		
4-2-1	No timer tick	See " <a href="#">Troubleshooting Expansion Cards</a> " in "Troubleshooting Your System." See " <a href="#">Troubleshooting System Memory</a> " in "Troubleshooting Your System." Install memory modules of the same type and size in bank 1 (see " <a href="#">Installing Memory Modules</a> " in "Installing System Options"). See " <a href="#">Troubleshooting the I/O Board</a> " in "Troubleshooting Your System." See " <a href="#">Troubleshooting the System Battery</a> " and " <a href="#">Troubleshooting the I/O Riser Card</a> " in "Troubleshooting Your System." See " <a href="#">Troubleshooting the I/O Riser Card</a> " in "Troubleshooting Your System." See " <a href="#">Troubleshooting the I/O Board</a> " and " <a href="#">Troubleshooting System Memory</a> " in "Troubleshooting Your System." See " <a href="#">Troubleshooting the Microprocessor Board</a> " in "Troubleshooting Your System."	
4-2-2	Shutdown test failure		
4-2-3	Gate A20 failure		
4-2-4	Unexpected interrupt in protected mode		
4-3-1	Improperly installed or faulty memory modules		
4-3-2	No memory modules installed in bank 1		
4-3-3	Faulty I/O board		
4-3-4	Time-of-day clock stopped		
4-4-1	Super I/O chip failure; faulty I/O riser card		
4-4-2	BIOS-shadowing failure		
4-4-3	Microprocessor speed control sequence failure		
4-4-4	Cache test failure; faulty microprocessor		

**NOTE:** For the full name of an abbreviation or acronym used in this table, see "[Abbreviations and Acronyms](#)."

## Warning Messages

A warning message alerts you to a possible problem and asks you to take corrective action before the system continues a task. For example, before you format a diskette, a message may warn you that you may lose all data on the diskette. Warning messages usually interrupt the procedure and require you to respond by typing y (yes) or n (no).

 **NOTE:** Warning messages are generated by either the application program or the operating system. For more information, see "[Finding Software Solutions](#)" and the documentation that accompanied the operating system or application program.

## Diagnostics Messages

When you run a test group or subtest in system diagnostics, an error message may result. Diagnostic error messages are not covered in this section. Record the message on a copy of the Diagnostics Checklist (see "[Getting Help](#)"), and then follow the instructions in that section for obtaining technical assistance.

## Alert Messages

The optional systems management software generates alert messages for your system. For example, the software generates messages that appear in the SNMP trap log file. Alert messages consist of information, status, warning, and failure messages for drive, temperature, fan, and power conditions. For more

information, see the systems management software documentation.

---

[Back to Contents Page](#)

[Back to Contents Page](#)

## Finding Software Solutions

Dell™ PowerEdge™ 6600 Systems Installation and Troubleshooting Guide

- [Installing and Configuring Software](#)
- [Using Software](#)

Because most systems have several application programs installed in addition to the operating system, isolating a software problem can be confusing. Software errors can also appear to be hardware malfunctions at first.

Software problems can result from the following circumstances:

- 1 Improper installation or configuration of a program
- 1 Input errors
- 1 Device drivers that may conflict with certain application programs
- 1 Interrupt conflicts between devices

You can confirm that a system problem is caused by software by running the system diagnostics. If all tests in the test group are completed successfully, the problem is most likely caused by software.

This section provides some general guidelines for analyzing software problems. For detailed troubleshooting information on a particular program, see the documentation that accompanied the software or consult the support service for the software.

---

### Installing and Configuring Software

Use virus-scanning software to check newly acquired programs and files for viruses before installing the programs on the system's hard drive. Viruses can quickly use all available system memory, damage or destroy data stored on the hard drive, and permanently affect the performance of the programs they infect. Several commercial virus-scanning programs are available for purchase.

Before installing a program, read its documentation to learn how the program works, what hardware it requires, and what its defaults are. A program usually includes installation instructions in its accompanying documentation and a software installation routine.

The software installation routine assists users in transferring the appropriate program files to the system's hard drive. Installation instructions may provide details about how to configure the operating system to successfully run the program. Always read the installation instructions before running a program's installation routine.

When you run the installation routine, be prepared to respond to prompts for information about how the system's operating system is configured, what type of system you have, and what peripherals are connected to the system.

---

### Using Software

The following subsections discuss errors that can occur as a result of software operation or configuration.

#### Error Messages

Error messages can be produced by an application program, the operating system, or the system. "[Indicators, Messages, and Codes](#)" discusses the error messages that are generated by the system. If you receive an error message that is not listed in "[Indicators, Messages, and Codes](#)," check the operating system or application program documentation.

#### Input Errors

If a specific key or set of keys is pressed at the wrong time, a program may give you unexpected results. See the documentation that came with the application program to make sure that the values or characters you are entering are valid.

Make sure that the operating environment is set up to accommodate the programs you use. Keep in mind that whenever you change the parameters of the system's operating environment, you may affect the successful operation of the programs. Sometimes, after modifying the operating environment, you may need to reinstall a program that no longer runs properly.

#### Program Conflicts

Some programs may leave portions of their setup information behind, even though you have exited from them. As a result, other programs cannot run. Rebooting the system can confirm whether these programs are the cause of the problem.

Device drivers, which are programs that use specialized subroutines, can cause problems with the system. For example, a variation in the way the data is sent to the monitor may require a special screen driver program that expects a certain kind of video mode or monitor. In such cases, you may have to develop an alternate method of running that particular program—by creating a start-up file made especially for that program, for example. Contact the support service for the software you are using to help you with this problem.

#### Avoiding Interrupt Assignment Conflicts

Most PCI devices can share an IRQ line with another device. However, no two devices can use the IRQ line simultaneously. Problems can arise if a PCI device cannot share an IRQ line or if two devices attempt to use the same IRQ line simultaneously. To avoid this type of conflict, see the documentation for each installed expansion card. Consult [Table 3-1](#) to configure the card for one of the available IRQ lines.

**Table 3-1. IRQ Line Assignment Defaults**

IRQ Line	Used By/Available
IRQ0	Used by the system timer
IRQ1	Used by the keyboard controller
IRQ2	Used by interrupt controller 1 to enable IRQ8 through IRQ15
IRQ3	Available
IRQ4	Used by serial port 1 (COM1 and COM3)
IRQ5	Available
IRQ6	Used by the diskette-drive controller
IRQ7	Available
IRQ8	Used by the real-time clock
IRQ9	Used for power management functions
IRQ10	Available
IRQ11	Available
IRQ12	Used by the PS/2 mouse port unless the mouse is disabled in the System Setup program
IRQ13	Used by the math coprocessor
IRQ14	IDE CD drive controller
IRQ15	Embedded server management

**NOTE:** For the full name of an abbreviation or acronym used in this table, see "[Abbreviations and Acronyms](#)."

---

[Back to Contents Page](#)

[Back to Contents Page](#)

## Running the System Diagnostics

Dell™ PowerEdge™ 6600 Systems Installation and Troubleshooting Guide

- [Features of the System Diagnostics](#)
- [When to Use the System Diagnostics](#)
- [Starting the System Diagnostics](#)
- [How to Use the System Diagnostics](#)
- [How to Use the Device Groups Menu](#)
- [Device Groups Menu Options](#)
- [Error Messages](#)

Unlike many diagnostic programs, the system diagnostics helps you check the system's hardware without any additional equipment and without destroying any data. By using the diagnostics, you can have confidence in the system's operation. If you find a problem that you cannot solve by yourself, the diagnostic tests can provide you with important information you will need when talking to a technical assistance representative.



**NOTICE:** Use the system diagnostics to test only Dell™ systems. If you use this program with other systems, incorrect system responses or error messages may result.

---

## Features of the System Diagnostics

The system diagnostics provides a series of menus and options from which you choose particular device groups or devices. You can also control the sequence in which the tests are run. The diagnostic menus also have these helpful features:

- 1 Options that let you run tests individually or collectively
- 1 An option that allows you to choose the number of times a test is repeated
- 1 The ability to display or print test results or to save them in a file
- 1 Options to temporarily suspend testing if an error is detected or to terminate testing when an adjustable error limit is reached
- 1 Help messages that briefly describe each test and its parameters
- 1 Status messages that inform you whether device group or device tests are completed successfully
- 1 Error messages that appear if any problems are detected

---

## When to Use the System Diagnostics

Whenever a major component or device in the system does not function properly, you may have a component failure. As long as the microprocessor and the input and output components of the system (the monitor, keyboard, and diskette drive) are working, you can use system diagnostics. If you know what component(s) you need to test, simply select the appropriate diagnostic device group(s) or subtest(s). If you are unsure about the scope of the problem, read the rest of the information in this section.

---

## Starting the System Diagnostics

You can run system diagnostics from either the utility partition on your hard drive or from a set of diskettes that you create from the *Dell OpenManage Server Assistant* CD.

To run the diagnostics from the utility partition, perform the following steps:

1. Start the utility partition by pressing <F10> during POST.
2. From the utility partition's main menu, select the **Run System Diagnostics** option from **Run System Utilities**.

See "Using the Dell OpenManage Server Assistant CD" in the *User's Guide* for additional information about the utility partition.

To run the system diagnostics from the diskettes, perform the following steps:

1. Create a set of diagnostics diskettes using the *Dell OpenManage Server Assistant* CD.

See "Using the Dell OpenManage Server Assistant CD" in the *User's Guide* for information on creating diskettes.

2. Boot the system from the first diagnostics diskette.

If the system fails to boot, see "[Getting Help](#)."

When you start the diagnostics, a message is displayed telling you that the diagnostics is loading. The **Diagnostics** menu appears. The menu allows you to run all or specific diagnostic tests or to exit system diagnostics.



**NOTE:** Before you read the rest of this section, start the system diagnostics so that you can see it on your monitor screen.

For a quick check of the system, select **Test All Devices** and then select **Quick Tests**. This option runs only the device tests that do not require user

interaction and that do not take a long time to run. Dell recommends that you choose this option first to increase the chance of tracing the source of the problem quickly. To test a particular device, select **Test One Device**. For a complete check of the system, select **Test All Devices** and then select **Extended Tests**.

To check a particular area of the system, choose **Advanced Testing**. When you select **Advanced Testing**, the main screen of the diagnostics appears. This screen includes a listing of the various device groups in the system and the system's service tag.

To view data on test results, select **Information and Results**. Select **Program Options** to view the program options screen, which lets you set various test parameters.

By selecting the **Device Configuration** option, you can see an overview of the devices in the system.

Selecting **Exit to MS-DOS** exits the diagnostics and returns you to the MS-DOS® operating system environment.

To select an option from the **Diagnostics** menu, highlight the option and press <Enter>, or press the key that corresponds to the highlighted letter in the option you choose.

---

## How to Use the System Diagnostics

When you select **Advanced Testing** from the **Diagnostics** menu, the main screen of the diagnostics appears.

Information on the main screen of the diagnostics is presented in the following areas:

- 1 Two lines at the top of the main screen identify the diagnostics, the version number, and the system service tag.
- 1 On the left side of the screen, the **Device Groups** area lists the diagnostic device groups in the order they will run if you select **All** under the **Run Tests** submenu. Press the up- or down-arrow key to highlight a device group.
- 1 On the right side of the screen, the **Devices for Highlighted Group** area lists the specific devices within a particular test group.
- 1 Two lines at the bottom of the screen make up the menu area. The first line lists the menu options you can select; press the left- or right-arrow key to highlight an option. The second line gives information about the highlighted option.

---

## How to Use the Device Groups Menu

The **Device Groups** menu at the bottom of the screen provides options that enable you to select and run specific diagnostic tests from the diagnostics main screen. Press the left- and right-arrow keys to select the options on the menu. As you move from one menu option to another, a brief explanation of the highlighted option appears on the bottom line of the screen.

If you want more information about a device group or device, highlight the **Help** option and press <Enter>. After you read the information, press <Esc> to return to the previous screen.

---

## Device Groups Menu Options

Five options are listed at the bottom of the diagnostics main screen: **Run Tests**, **Devices**, **Select**, **Config**, and **Help**.

There are two ways to select a menu option:

- 1 Look on the screen to see which letter in the option is capitalized, and type that letter (for example, type **r** to select the **Run** option).
- 1 Move the highlight to the option you want to select by pressing the left- or right-arrow key, and then press <Enter>.

Whenever one of the options is selected, additional choices become available.

The following subsections explain the menu options as listed from left to right in the **Device Groups** menu.

### Run Tests

**Run Tests** displays seven options: **One**, **All**, **Select**, **Options**, **Results**, **Errors**, and **Help**. If you select **One**, all the devices within the highlighted device group are run. If you select **All**, all of the tests in all of the device group tests are run. (The device group tests are run in the same order that they are listed.) If you choose **Select**, only the selected device groups or the devices that you selected within the device groups are run. Before you test any device groups or devices, consider setting global parameters within **Options**. Global parameters offer you greater control over how the device group tests or device tests are run and how results are reported. **Help** displays a series of help options, including **Menu**, **Keys**, **Device Group**, **Device**, **Test**, and **Versions**.

### Devices

Most of the device groups consist of several devices. Use the **Devices** option to select individual devices within the device group(s).

When you select **Devices**, the following options are displayed: **Run Tests**, **Tests**, **Select**, **Parameters**, and **Help**. [Table 4-1](#) lists all of the possible values for each option.

Table 4-1. Devices Options

Option	Functions
Run Tests	Displays seven options: <b>One</b> , <b>All</b> , <b>Select</b> , <b>Options</b> , <b>Results</b> , <b>Errors</b> , and <b>Help</b> .



Tests	Allows you to select individual devices to tailor the testing process to your particular needs. You can choose one or more devices from the list. When you choose <b>Tests</b> , four options are displayed: <b>Run Tests</b> , <b>Select</b> , <b>Parameters</b> , and <b>Help</b> .
Select	Allows you to choose one or more devices from a particular device group. Three options are displayed: <b>One</b> , <b>All</b> , and <b>Help</b> .
Parameters	Determines how a particular test will be run.
Help	Displays a list of help topics.

## Select

The **Select** option in the **Device Groups** menu allows you to choose one or more devices from a particular device group. Three options are displayed: **One**, **All**, and **Help**.

## Config

Choosing **Config** from the **Device Groups** menu displays information about the particular device that is highlighted.

---

## Error Messages

When you run a test in the diagnostics, error messages may result. Record the messages on a copy of the Diagnostics Checklist; see "[Getting Help](#)" for instructions on obtaining technical assistance and informing the technical assistance representative of these messages.

---

[Back to Contents Page](#)

[Back to Contents Page](#)

## Troubleshooting Your System

### Dell™ PowerEdge™ 6600 Systems Installation and Troubleshooting Guide

- [Safety First—For You and Your System](#)
- [Before You Begin](#)
- [External Connections](#)
- [Checking Specific System Problems](#)
- [Start-Up Routine](#)
- [System Orientation](#)
- [Bezel](#)
- [System Covers](#)
- [Checking the Equipment](#)
- [Inside the System](#)
- [Responding to a Systems Management Alert Message](#)
- [Troubleshooting a Wet System](#)
- [Troubleshooting a Damaged System](#)
- [Troubleshooting the System Battery](#)
- [Troubleshooting Power Supplies](#)
- [Troubleshooting System Cooling](#)
- [Troubleshooting the Microprocessor Board](#)
- [Troubleshooting the I/O Riser Card](#)
- [Troubleshooting the I/O Board](#)
- [Troubleshooting Expansion Cards](#)
- [Troubleshooting System Memory](#)
- [Troubleshooting the Diskette Drive](#)
- [Troubleshooting a CD Drive](#)
- [Troubleshooting SCSI Tape Drives](#)
- [Troubleshooting Hard Drives](#)
- [Troubleshooting a RAID Controller Card](#)

If your system is not working as expected, begin troubleshooting by using the procedures in this section. This section guides you through some initial checks and procedures that can solve basic system problems and provides troubleshooting procedures for components inside the system. Before you start any of the procedures in this section, take the following steps:



- 1 Read the "Safety Instructions" in your *System Information* document.
- 1 Read "[Running the System Diagnostics](#)" for information about running diagnostics.
- 1 Get the key to the system's keylock and back cover.

---

## Safety First—For You and Your System

The procedures in this guide require that you remove the cover and work inside the system. While working inside the system, do not attempt to service the system except as explained in this guide and elsewhere in your system documentation. Always follow the instructions closely. Make sure to review all of the procedures in "Safety Instructions" in your *System Information* document.

Working inside the system is safe—if you observe the following precautions.

-  **CAUTION:** The power supplies in this system produce high voltages and energy hazards, which can cause bodily harm. Only trained service technicians are authorized to remove the system cover and access any of the components inside the system.
-  **NOTICE:** See "Protecting Against Electrostatic Discharge" in the safety instructions in your *System Information* document before performing any procedure which requires you to open the cover.

---

## Before You Begin

Before you perform any of the procedures, ensure that the following components are securely and properly installed:

- 1 Power cables
- 1 Cables to external devices, such as monitor, mouse, and keyboard
- 1 Microprocessor tray

---

## External Connections

Improperly set switches, controls, and loose or improperly connected cables are the most likely source of problems for the system, monitor, or other peripherals (such as a printer, keyboard, mouse, or other external equipment). A quick check of all the switches, controls, and cable connections can easily solve these problems. See [Figure 2-3](#) for the back-panel features and connectors.

---

## Checking Specific System Problems

1. Turn off the system, including any attached peripherals, and disconnect all power cables from their electrical outlets.
2. If the system is connected to a PDU, turn the PDU off and then on again.  
  
If the PDU is not receiving power, plug it into another electrical outlet. If it still is not receiving power, try another PDU.
3. Reconnect the system to the electrical outlet or PDU.
4. Is the monitor working properly?

See "[Troubleshooting the Video Subsystem.](#)"

5. Is the keyboard working properly?

See "[Troubleshooting the Keyboard.](#)"

6. Are the mouse and printer working properly?

See "[Troubleshooting the Basic I/O Functions.](#)"

---

## Start-Up Routine

Looking at and listening to the system is important in determining the source of a problem. Look and listen during the system's start-up routine for the indications described in [Table 5-1](#).

**Table 5-1. Start-Up Routine Indications**

Look/listen for:	Action
A status or error message displayed on the front-panel LCD	See " <a href="#">LCD Status Messages</a> " in "Indicators, Messages, and Codes."
An error message displayed on the monitor	See " <a href="#">System Messages</a> " in "Indicators, Messages, and Codes."
A series of beeps emitted by the system	See " <a href="#">System Beep Codes</a> " in "Indicators, Messages, and Codes."
Alert messages from the Dell OpenManage™ Server Administrator software	See " <a href="#">Alert Messages</a> " in "Indicators, Messages, and Codes."
The monitor's power indicator	See " <a href="#">Troubleshooting the Video Subsystem.</a> "
The keyboard indicators	See " <a href="#">Troubleshooting the Keyboard.</a> "
The diskette-drive activity indicator	See " <a href="#">Troubleshooting the Diskette Drive.</a> "
The CD drive activity indicator	See " <a href="#">Troubleshooting a CD Drive.</a> "
The hard-drive activity indicators	See " <a href="#">Troubleshooting Hard Drives.</a> "
An unfamiliar constant scraping or grinding sound when you access a drive	See " <a href="#">Getting Help</a> " for instructions on obtaining technical assistance.
<b>NOTE:</b> For the full name of an abbreviation or acronym used in this table, see " <a href="#">Abbreviations and Acronyms.</a> "	

---

## System Orientation

[Figure 5-1](#) shows the rack and tower versions of your system. The illustrations in this document are based on the tower version with the system laying on its right side.

**Figure 5-1. System Orientation**

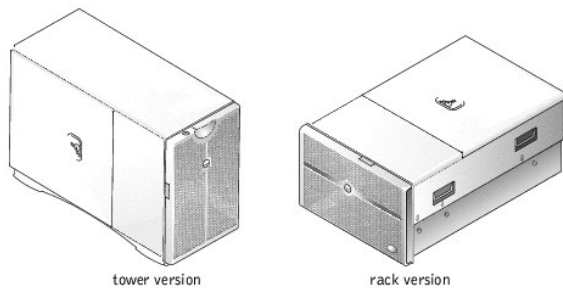

---

## Bezel

The bezel has status and caution indicators. Opening or removing the bezel provides access to the power switch, diskette drive, CD drive, and hard drive(s). You must open the bezel and remove the system covers to gain access to internal components.

### Opening the Bezel

1. Using the system key, unlock the bezel if it is locked.
2. Pull the bezel away from the system so that it is perpendicular to the system (see [Figure 5-2](#)).

**Figure 5-2. Opening the Bezel**

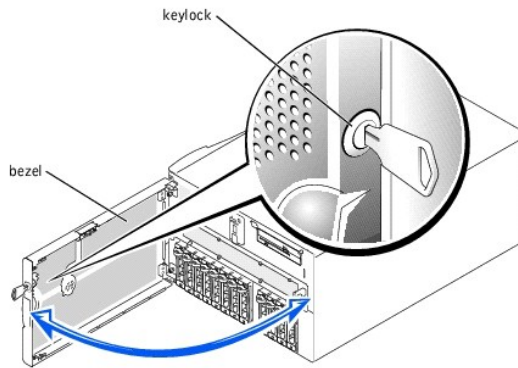

### Closing the Bezel

1. Swing the bezel closed until it snaps into place.
2. Using the system key, lock the bezel.

## System Covers

The system is enclosed by a bezel and two covers. To upgrade or troubleshoot the system, remove the system covers to gain access to internal components. The back cover must be removed before removing the front cover.

### Removing the Back Cover

1. Using the system key, unlock the back cover if it is locked.
2. Observe the precautions in "[Safety First—For You and Your System.](#)"
3. Loosen the thumbscrew that secures the back cover to the chassis (see [Figure 5-3](#)).

Figure 5-3. Removing and Replacing the Back Cover

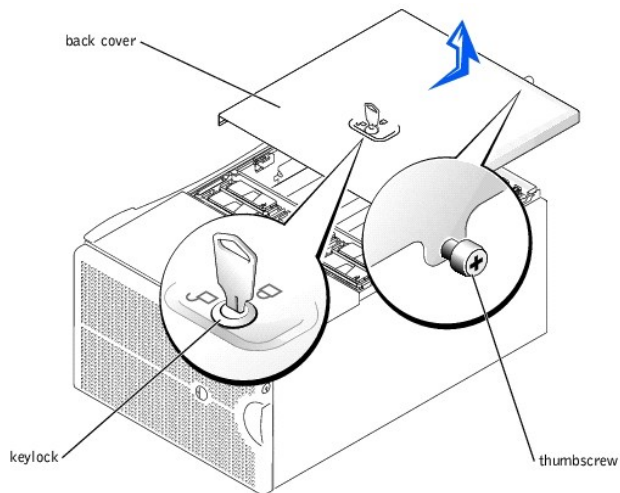

4. Slide the back cover backward and grasp the cover at both ends.
5. Carefully lift the cover away from the system.

### Replacing the Back Cover

1. Check that no tools or parts are left inside the system and that any cables are routed so that they will not be damaged by the cover.
2. Align the cover with the cover alignment notches on the sides of the chassis, and slide the cover forward (see [Figure 5-3](#)).
3. Tighten the thumbscrew that secures the cover to the chassis (see [Figure 5-3](#)).
4. Using the system key, lock the back cover.

## Removing the Front Cover

1. Remove the back cover (see ["Removing the Back Cover"](#)).
2. Slide the front cover backward and grasp the cover at both ends (see [Figure 5-4](#)).
3. Carefully lift the cover away from the system.

Figure 5-4. Removing and Replacing the Front Cover

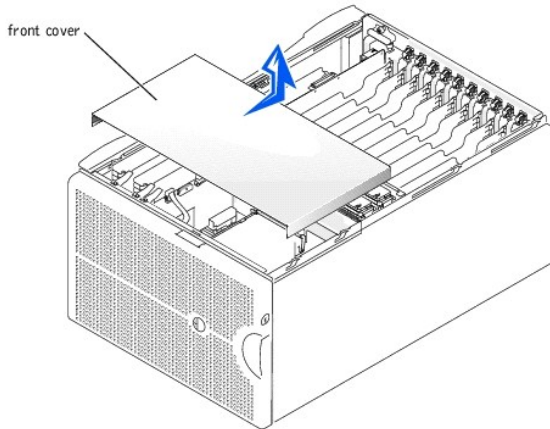

## Replacing the Front Cover

1. Check that no tools or parts are left inside the system and that any cables are routed so that they will not be damaged by the cover.
2. Align the cover with the cover alignment notches on the sides of the chassis, and slide the cover forward (see [Figure 5-4](#)).
3. Replace the back cover (see ["Replacing the Back Cover"](#)).

---

## Checking the Equipment

This section provides troubleshooting procedures for equipment that connects directly to the I/O riser card, such as the monitor, keyboard, or mouse. Before you perform any of the procedures, see ["External Connections."](#)

### Troubleshooting the Video Subsystem

#### Problem

- 1 Monitor
- 1 Monitor interface cable
- 1 Video memory
- 1 Video logic

#### Action

1. Check the system and power connections to the monitor.
2. Determine whether the system has a remote access card and a video expansion card installed.

The system supports only the embedded video when using a remote access card.

If a video expansion card is not installed, go to step 3.

If a video expansion card is installed, remove the video card (see ["Removing an Expansion Card"](#) in "Installing System Options"). If the problem persists, go to step 3.

3. Run the video tests in the system diagnostics.

If the tests run successfully, the problem is not related to video hardware. Go to ["Finding Software Solutions."](#)

If the tests did not run successfully, see ["Getting Help"](#) for instructions on obtaining technical assistance.

### Troubleshooting the Keyboard

#### Problem

- 1 System error message indicates a keyboard problem

#### Action

1. Look at the keyboard and the keyboard cable for any signs of damage.

If the keyboard and its cable appear to be free of physical damage and the keys work, go to step 3.

If the keyboard or its cable are damaged, continue to step 2.

2. Swap the faulty keyboard with a working keyboard.

If the problem is resolved, the keyboard must be replaced (see "[Getting Help](#)" for instructions on obtaining technical assistance).

3. Run the keyboard test in the system diagnostics.

If you can use the keyboard to select the keyboard test, go to step 4.

If the test did not run successfully, see "[Getting Help](#)" for instructions on obtaining technical assistance.

4. Swap the faulty keyboard with a working keyboard.

If the problem is resolved, the faulty keyboard must be replaced.

If the problem is not resolved, the keyboard controller on the I/O riser card is faulty (see "[Getting Help](#)" for instructions on obtaining technical assistance).

## Troubleshooting the Mouse

#### Problem

- 1 System error message indicates a mouse problem

#### Action

1. Look at the mouse and the mouse cable for any signs of damage.

2. Click each button on the mouse.

If the mouse and its cable appear to be free of physical damage and the buttons work, go to step 4.

If the mouse or its cable are damaged, continue to step 3.

3. Swap the faulty mouse with a working mouse.

If the problem is resolved, the mouse must be replaced (see "[Getting Help](#)" for instructions on obtaining technical assistance).

4. Run the pointing devices test in the system diagnostics.

If the problem is resolved, the faulty mouse must be replaced.

If the problem is not resolved, the controller on the I/O riser card is faulty (see "[Getting Help](#)" for instructions on obtaining technical assistance).

## Troubleshooting the Basic I/O Functions

#### Problem

- 1 System error message indicates an I/O port problem
- 1 Device connected to the port is not working

#### Action

1. Enter the System Setup program (see "Using the System Setup Program" in the *User's Guide* for instructions) and check the **Serial Port 1** setting.

If the communications port is set to **Off**, go to step 3.

If the communications port is not set to **Off**, continue to step 2.

2. Change the **Serial Port 1** setting to **Auto**; then reboot the system.

3. Check the settings in the System Setup program.

See "Using the System Setup Program" in the *User's Guide* for instructions. If the settings are correct, go to step 5.

4. Change the necessary settings in the System Setup program. If the port problem is confined to a particular application program, see the application program's documentation for specific port configuration requirements.

5. Reboot the system from the diagnostics diskette, and run the serial port test in the system diagnostics.

If the test did not run successfully, see "[Getting Help](#)" for instructions on obtaining technical assistance.

If the test runs successfully but the problem persists, see "[Troubleshooting a Serial I/O Device](#)."

## Troubleshooting a Serial I/O Device

### Problem

- 1 Device connected to the serial port is not working

### Action

1. Open the front bezel (see "[Opening the Bezel](#)").
2. Turn off the system and any peripheral devices connected to the serial port.
3. Swap the interface cable with a known working cable.

If the problem is resolved, the interface cable must be replaced (see "[Getting Help](#)" for instructions on obtaining technical assistance).

4. Turn off power to the system and the serial device, and swap the device with a comparable device.
5. Turn on the system and the serial device.

If the problem is resolved, the serial device must be replaced.

If the problem is not resolved, see "[Getting Help](#)" for instructions on obtaining technical assistance.

## Troubleshooting a USB Device

### Problem

- 1 System error message indicates problem
- 1 Device connected to the port is not working

### Action

1. Enter the System Setup program and ensure that the USB ports are enabled (see "Using the System Setup Program" in the *User's Guide* for instructions).
2. Open the front bezel (see "[Opening the Bezel](#)").
3. Turn off the system and any USB devices.

If there is only one USB device connected to the system, go to step 6.

4. Disconnect all USB devices, and connect the malfunctioning device to the other USB port.
5. Turn on the system and the reconnected device.

If the problem is resolved, the USB port may be defective (see "[Getting Help](#)" for instructions on obtaining technical assistance).

6. If possible, swap the interface cable with a known working cable.
- If the problem is resolved, the interface cable must be replaced (see "[Getting Help](#)" for instructions on obtaining technical assistance).
7. Turn off the system and the USB device, and swap the device with a comparable device.
8. Turn on the system and the USB device.

If the problem is resolved, the USB device must be replaced.

If the problem is not resolved, see "[Getting Help](#)" for instructions on obtaining technical assistance.

## Troubleshooting the NICs

### Problem

- 1 NICs cannot communicate with the network

### Action

1. Check the appropriate indicator on the NIC connector (see [Figure 2-6](#)).

A green indicator shows that the adapter is connected to a valid link partner. A blinking amber indicator shows that network data is being sent or received.

- 1 If the link indicator is not on, check all cable connections.
- 1 Try changing the auto-negotiation setting, if possible.
- 1 Try another port on the switch or hub.

If you are using a NIC expansion card instead of the integrated NICs, see the documentation for the NIC card.

2. If the indicator does not light, the network driver files might be damaged or deleted. Check the drivers, and remove and reinstall the drivers if applicable.

You must reboot your system for the reinstalled drivers to become active.

3. Ensure that the appropriate drivers are installed and the protocols are bound.
4. Enter the System Setup program and confirm that the NICs are enabled (see "Using the System Setup Program" in the *User's Guide*).
5. Ensure that the NICs, hubs, and switches on the network are all set to the same data transmission speed.
6. Ensure that all network cables are of the proper type and do not exceed the specified length. For more information, see "Network Cable Requirements" in the *User's Guide*.

---

## Inside the System

In [Figure 5-5](#), the system covers are removed and the bezel is opened to provide an interior view of the system.

**Figure 5-5. Inside the System**

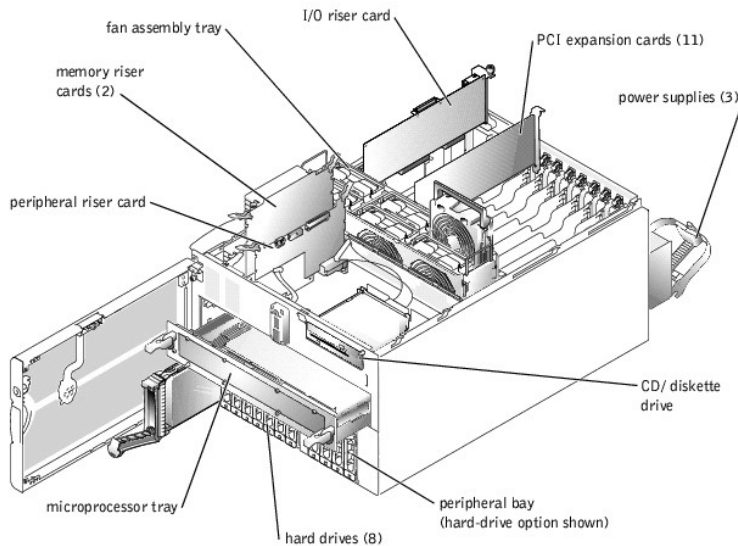

The I/O board can accommodate up to 11 PCI expansion cards (10 PCI or PCI-X cards at 64-bit/33–100 MHz and one PCI card at 32-bit/33 MHz). The system memory is contained on two separate riser cards that must be populated with at least two memory modules each for the system to operate. The peripheral bay provides space for four additional 1-inch SCSI hard drives or one tape drive.

The hard-drive bays provide space for up to eight 1-inch SCSI hard drives. These hard drives are connected to a RAID controller card through the SCSI backplane board.

The power distribution board (PDB) provides hot-plug logic and power distribution for the system. Your system can utilize an AC module or an optional, integrated, redundant AC power module to provide AC current to the hot-pluggable power supplies. The AC module is used when a redundant AC power source is not required. The integrated redundant AC power module enables your system to use two AC inputs. Your system can operate on either of these inputs and automatically switches from a failing AC power source. The three hot-pluggable power supplies slide into connectors mounted on the PDB and provide power to the system board, SCSI backplane board, and internal peripherals.

For non-SCSI drives such as the diskette drive and CD drive, an interface cable connects the interposer board, attached to the CD/diskette drive tray, to the peripheral riser card. For SCSI devices, interface cables connect externally accessible SCSI devices and the SCSI backplane board to a SCSI host adapter on either the I/O riser card or an expansion card (for more information, see "[Installing Drives](#)").

During an installation or troubleshooting procedure, you may be required to change a jumper. For information on jumpers, see "[Jumpers and Connectors](#)."

---

## Responding to a Systems Management Alert Message

The optional systems management applications monitor critical system voltages and temperatures, the system cooling fans, and the status of the SCSI hard drives in the system. Alert messages appear in the alert log window. For information about the alert log window and options, see your systems management software documentation.

---

## Troubleshooting a Wet System

### Problem

- 1 Liquid spills
- 1 Splashes



- 1 Excessive humidity

#### Action

1. Turn off the system, including any attached peripherals, and disconnect the system from the electrical outlet.
2. Remove the back cover (see "[Removing the Back Cover](#)").
3. Remove the front cover (see "[Removing the Front Cover](#)").
4. Remove all expansion cards installed in the system (see "[Removing an Expansion Card](#)" in "Installing System Board Options").
5. Let the system dry thoroughly for at least 24 hours.
6. Replace the system covers, reconnect the system to the electrical outlet, and turn on the system.

If the system does not start up properly, see "[Getting Help](#)" for instructions on obtaining technical assistance.

7. If the system starts up normally, shut down the system and reinstall all expansion cards that were removed in step 4 (see "[Installing an Expansion Card](#)" in "Installing System Board Options").
8. Run the system board tests in the system diagnostics to confirm that the system is working properly.

If the tests did not complete successfully, see "[Getting Help](#)" for instructions on obtaining technical assistance.

---

## Troubleshooting a Damaged System

#### Problem

- 1 System dropped or damaged

#### Action

1. Ensure that all cables are properly connected.
2. Ensure that all components are properly installed and are free from damage.
3. Run the system board tests in the system diagnostics.

If the tests did not complete successfully, see "[Getting Help](#)" for instructions on obtaining technical assistance.

---

## Troubleshooting the System Battery

#### Problem

- 1 Error message shows a problem with the battery
- 1 System Setup program loses system configuration information
- 1 System date and time do not stay current

The system battery maintains system configuration, date, and time information in a special section of memory when you turn off the system. The operating life of the battery ranges from 2 to 5 years, depending on how you use the system (for example, if you keep the system on most of the time, the battery gets little use and thus lasts longer). You may need to replace the battery if an incorrect time or date is displayed during the boot routine.

You can operate the system without a battery; however, the system configuration information maintained by the battery in NVRAM is erased each time you remove power from the system. Therefore, you must re-enter the system configuration information and reset the options each time the system boots until you replace the battery.

#### Action

1. Re-enter the time and date through the System Setup program (see "Using the System Setup Program" in the *User's Guide* for instructions).
2. Turn off and disconnect the system from the electrical outlet for a few hours.
3. Reconnect the system to the electrical outlet and turn the system on again.
4. Enter the System Setup program.

If the date and time are not correct in the System Setup program, replace the battery (see "[System Battery](#)").

If the problem is not resolved by replacing the battery, see "[Getting Help](#)" for instructions on obtaining technical assistance.

 **NOTE:** Some software may cause the system time to speed up or slow down. If the system seems to operate normally except for the time kept in the System Setup program, the problem may be caused by software rather than by a defective battery.

 **NOTE:** If the system is turned off for long periods of time (weeks or months), the NVRAM may lose its system configuration information. This situation is not caused by a defective battery.

---

## Troubleshooting Power Supplies

### Problem

- 1 System caution indicator is amber
- 1 Front-panel status LCD indicates a problem with power supply
- 1 Power-supply fault indicator signifies a problem

### Action

1. Locate the faulty power supply.

The power supply's fault indicator is lit (see [Figure 2-5](#)).

 **NOTICE:** The power supplies are hot-pluggable. The system requires two power supplies to be installed for the system to operate normally. Remove and replace only one power supply at a time in a system that is powered on.

2. Squeeze the power-supply handle's release tab and rotate the handle down.
3. Slide the power supply out until it clears the chassis.
4. Slide the new power supply into the chassis until it stops.
5. Rotate the handle up until it snaps into place.

If the problem persists, see "[Getting Help](#)" for instructions on obtaining technical assistance.

---

## Troubleshooting System Cooling

Cooling of the entire system as well as individual components can be affected by the following:

- 1 Ambient temperature surrounding the system is too high.
- 1 Airflow intake and output are obstructed.
- 1 Cables inside the system obstruct cooling fan intake or output.
- 1 Systems management software issues a fan-related error message.
- 1 An individual cooling fan has failed (see "[Troubleshooting a Cooling Fan](#)").
- 1 Expansion-card filler brackets are not installed over empty expansion slots.
- 1 A heat sink is not installed for each microprocessor.

 **NOTICE:** If a microprocessor socket does not have a microprocessor installed, a heat sink blank must be installed for that socket.

## Troubleshooting a Cooling Fan

### Problem

- 1 System caution indicator is amber
- 1 Front-panel status LCD indicates a problem with cooling
- 1 Fan status indicator signifies a problem with the fan
- 1 Systems management software issues a fan-related error message

### Action

1. Remove the back cover (see "[Removing the Back Cover](#)").
2. Locate the faulty fan.

 **NOTE:** Each individual fan has a status indicator. If the fan is operating normally, the indicator is green. If the fan is malfunctioning, the indicator is blinking amber.

 **NOTICE:** The cooling fans are hot-pluggable. To maintain proper cooling while the system is on, replace only one fan at a time.

3. Remove the fan (see "[Removing a Cooling Fan](#)" in "Installing System Options").
4. Reseat the fan in its compartment and ensure that the fan connector is firmly seated.
5. If the problem is not resolved, install a new fan (see "[Replacing a Cooling Fan](#)" in "Installing System Options").
6. If the new fan does not operate, the fan connector is faulty (see "[Getting Help](#)" for information on obtaining technical assistance).

 **NOTE:** After installing a new fan, allow up to 30 seconds for the system to recognize the fan and determine whether it is working properly.

---

## Troubleshooting the Microprocessor Board

## Problem

- 1 Error message indicates a microprocessor problem
- 1 Error message indicates a microprocessor board problem
- 1 Front-panel status LCD indicates a problem with microprocessors, VRMs, or the microprocessor board
- 1 A heat sink is not installed for each microprocessor

 **NOTICE:** If a microprocessor socket does not have a microprocessor installed, a heat sink blank must be installed for that socket.

## Action

1. Observe the precautions in "[Safety First—For You and Your System.](#)"
2. Turn off the system, including any attached peripherals, and disconnect the system from its electrical outlet.

 **NOTICE:** See "Protecting Against Electrostatic Discharge" in the safety instructions in your *System Information* document.

3. Remove the microprocessor tray (see "[Removing the Microprocessor Tray.](#)").
4. Ensure that VRMs are installed for each microprocessor and reseat the VRMs.
5. Replace the microprocessor tray (see "[Replacing the Microprocessor Tray.](#)").
6. Reconnect the system to its electrical outlet and turn the system on, including any attached peripherals.
7. Run the **Quick Tests** in the system diagnostics.

If the problem persists, go to step 8.

8. Turn off the system, including any attached peripherals, and disconnect the system from its electrical outlet.
9. Remove the microprocessor tray (see "[Removing the Microprocessor Tray.](#)").
10. Remove all microprocessors and VRMs except CPU1 and VRM1 (see "[Adding or Replacing a Microprocessor.](#)").

If there is only one microprocessor installed, see "[Getting Help.](#)"

11. Replace the microprocessor tray (see "[Replacing the Microprocessor Tray.](#)").
12. Reconnect the system to its electrical outlet and turn the system on, including any attached peripherals.
13. Run the **Quick Tests** in the system diagnostics.

If the tests complete successfully, go to step 14.

14. Turn off the system, including any attached peripherals, and disconnect the system from its electrical outlet.
15. Remove the microprocessor tray (see "[Removing the Microprocessor Tray.](#)").
16. Reinstall one of the microprocessors and VRMs that you removed in step 10 (see "[Adding or Replacing a Microprocessor.](#)").
17. Repeat steps 11 through 16 for each microprocessor and VRM removed in step 10.

If the problem persists, see "[Getting Help.](#)"

---

## Troubleshooting the I/O Riser Card

### Problem

- 1 Error message indicates an I/O riser card problem (mouse, keyboard, serial port, parallel port, NIC, video, SCSI, USB, BIOS, or BMC problem)

### Action

1. Observe the precautions in "[Safety First—For You and Your System.](#)"
2. Turn off the system, including any attached peripherals, and disconnect the system from its electrical outlet.
3. Remove the back cover (see "[Removing the Back Cover.](#)").
4. Disconnect all cables from the I/O riser card.

 **NOTICE:** See "Protecting Against Electrostatic Discharge" in the safety instructions in your *System Information* document.

5. Reseat the I/O riser card (see "[Replacing the I/O Riser Card.](#)").
6. Reconnect all cables to the I/O riser card.
7. Replace the back cover (see "[Replacing the Back Cover.](#)").
8. Reconnect the system to its electrical outlet, and turn on the system.

9. Perform the I/O devices tests in the system diagnostics.

If the problem persists, see "[Getting Help](#)."

---

## Troubleshooting the I/O Board

### Problem

1. Error message indicating an I/O board problem (expansion-card problem)

### Action

1. Observe the precautions in "[Safety First—For You and Your System](#)."
2. Turn off the system, including any attached peripherals, and disconnect the system from its electrical outlet.
3. Remove the back cover (see "[Removing the Back Cover](#)").

 **NOTICE:** See "Protecting Against Electrostatic Discharge" in the safety instructions in your *System Information* document.

4. Remove all expansion cards except the SCSI host-adapter card for the boot drive, if present (see "[Removing an Expansion Card](#)" in "Installing System Options").
5. Replace the back cover (see "[Replacing the Back Cover](#)").
6. Reconnect the system to its electrical outlet, and turn on the system.
7. Perform the PCI devices tests in the system diagnostics.

If the tests complete successfully, reinstall one of the expansion cards removed in step 4 (see "[Installing an Expansion Card](#)" in "Installing System Options").

If the problem persists, see "[Getting Help](#)."

8. Repeat steps 5 through 7 for each expansion card removed in step 4.

If any of the expansion cards fail a test, replace that card.

---

## Troubleshooting Expansion Cards

### Problem

1. Error message indicates an expansion-card problem
1. Expansion card seems to perform incorrectly or not at all
1. Expansion-card filler brackets are not installed over empty expansion slots

### Action

 **NOTICE:** When troubleshooting an expansion card, see the documentation for your operating system and the expansion card.

1. Observe the precautions in "[Safety First—For You and Your System](#)."
2. Remove the back cover (see "[Removing the Back Cover](#)").
3. Press the notify button for each expansion card and wait until the LED turns off (see [Figure 6-5](#)).
4. Verify that each expansion card is firmly seated in its connector.
5. Verify that any cables are firmly connected to their corresponding connectors on the expansion cards.
6. Press the notify button for each expansion card and wait until the green LED turns on.
7. Run the **Quick Tests** in the system diagnostics.

If the problem persists, go to step 8.

8. Press the notify button for each expansion card and wait until the LED turns off.
  9. Remove all expansion cards installed in the system.
  10. Run the **Quick Tests** in the system diagnostics.
- If the tests do not complete successfully, see "[Getting Help](#)" for information on obtaining technical assistance.
11. Reinstall one of the expansion cards removed in step 9, press the notify button for the expansion card, and wait until the green LED turns on.
  12. Repeat steps 10 and 11 for each of the remaining expansion cards.

If you have reinstalled all of the expansion cards and the **Quick Tests** are still failing, see "[Getting Help](#)."

---

## Troubleshooting System Memory

### Problem

- 1 Faulty memory module
- 1 Faulty memory riser card
- 1 Faulty microprocessor board

### Action

1. Turn on the system, including any attached peripherals.

If there are no error messages, go to step 18.

2. Enter the System Setup program to check the system memory setting (see "Using the System Setup Program" in the *User's Guide* for instructions).
3. If the amount of memory installed in the system matches the system memory setting, go to step 18.
4. Turn off the system, including any attached peripherals, and disconnect the system from its electrical outlet.
5. Remove the front cover (see "[Removing the Front Cover](#)").

 **NOTICE:** See "Protecting Against Electrostatic Discharge" in the safety instructions in your *System Information* document.

6. Remove the two memory riser cards (see "[Removing the Memory Riser Cards](#)" in "Installing System Options").
7. Reseat the memory modules in their sockets.
8. Reinstall the two memory riser cards (see "[Replacing the Memory Riser Cards](#)" in "Installing System Options").
9. Replace the front cover (see "[Replacing the Front Cover](#)").
10. Enter the System Setup program and check the system memory again.

If the amount of memory installed does not match the system memory setting, perform the following steps:

- a. Turn off the system.
  - b. Remove the back cover.
  - c. Remove the front cover.
  - d. Go to step 11.
11. Reboot the system and observe the monitor screen and the Num Lock, Caps Lock, and Scroll Lock indicators on the keyboard.

If the monitor screen remains blank and the Num Lock, Caps Lock, and Scroll Lock indicators on the keyboard remain on, perform the following steps:

- a. Turn off the system.
- b. Remove the back cover.
- c. Remove the front cover.
- d. Remove the memory riser cards.
- e. Go to step 12.

If the monitor screen does not remain blank and the Num Lock, Caps Lock, and Scroll Lock indicators on the keyboard remain on, continue to step 18.

 **NOTE:** There are multiple configurations for the memory modules; see "[Memory Module Installation Guidelines](#)" in "Installing System Board Options." The following steps are an example of one configuration.

12. Swap the memory module pair in bank 1 (sockets A and B) of both memory riser cards with another pair of the same capacity.
13. Reinstall the memory riser cards (see "[Replacing the Memory Riser Cards](#)").
14. Replace the front cover.
15. Replace the back cover, reconnect the system to its electrical outlet, and turn on the system.
16. Reboot the system, and observe the monitor screen and the indicators on the keyboard.
17. If the problem still exists, perform the following steps:
  - a. Turn off the system.
  - b. Remove the back cover.
  - c. Remove the front cover.
  - d. Remove the memory riser cards.
  - e. Repeat steps 12 through 16 for each memory module pair installed on each riser card.

If the problem is not resolved, see "[Getting Help](#)."

18. Run the system memory test in the system diagnostics.

If the test does not complete successfully, see "[Getting Help](#)."

---

## Troubleshooting the Diskette Drive

### Problem

- 1 Error message indicates a diskette-drive problem

### Action

1. Enter the System Setup program and verify that the system is configured correctly (see "Using the System Setup Program" in the *User's Guide*).
2. Open the bezel (see "[Opening the Bezel](#)").
3. Run the diskette drive tests from the diagnostics diskette to see whether the diskette drive works correctly.

If the tests failed, continue to step 4.

4. Turn off the system, including any attached peripherals, and disconnect the system from its electrical outlet.
5. Ensure that the CD/diskette drive assembly is properly installed (see "[Removing the CD/Diskette Drive Tray](#)" in "Installing Drives").
6. Connect the system to its electrical outlet and turn on the system, including any attached peripherals.
7. Run the diskette drive tests from the diagnostics diskette to see whether the diskette drive works correctly.

If the tests failed, continue to step 8.

8. Turn off the system, including any attached peripherals, and disconnect the system from its electrical outlet.
9. Remove the back cover (see "[Removing the Back Cover](#)").
10. Remove the front cover (see "[Removing the Front Cover](#)").
11. Ensure that the CD/diskette drive interface cable is securely connected to the interposer board on the CD/diskette drive assembly and to the peripheral riser card.
12. Ensure that the peripheral riser card is properly installed (see "[Removing the Peripheral Riser Card](#)" in "Installing System Options").
13. Replace the front cover (see "[Replacing the Front Cover](#)").
14. Replace the back cover (see "[Replacing the Back Cover](#)").
15. Connect the system to its electrical outlet and turn on the system, including any attached peripherals.
16. Run the diskette drive tests from the diagnostics diskette to see whether the diskette drive works correctly.
17. If the drive still does not work, remove all expansion cards (see "[Removing an Expansion Card](#)" in "Installing System Options").
18. Run the diskette drive tests from the diagnostics diskette to see whether the diskette drive works correctly.

If the test ran successfully, an expansion card may be conflicting with the diskette drive logic, or you may have a faulty expansion card. Continue to step 19.

If the test failed, see "[Getting Help](#)" for instructions on obtaining technical assistance.

19. Reinstall one of the expansion cards removed in step 17 (see "[Installing an Expansion Card](#)" in "Installing System Options").
20. Run the diskette drive tests from the diagnostics diskette to see whether the diskette drive works correctly.
21. Repeat steps 19 and 20 until all expansion cards have been reinstalled or until one of the expansion cards prevents the system from booting from the diagnostics diskette.

If the problem is not resolved, see "[Getting Help](#)" for instructions on obtaining technical assistance.

---

## Troubleshooting a CD Drive

### Problem

- 1 System cannot read data from a CD
- 1 CD drive indicator fails to flash during boot

### Action

1. Enter the System Setup program to ensure that the IDE device is enabled (see "Using the System Setup Program" in the *User's Guide*).
2. Open the bezel (see "[Opening the Bezel](#)").
3. Run the IDE devices tests in the system diagnostics to determine whether the CD drive works correctly.

If the tests failed, continue to step 4.

4. Turn off the system, including any attached peripherals, and disconnect the system from its electrical outlet.
5. Ensure that the CD/diskette drive assembly is properly installed (see "[Removing the CD/Diskette Drive Tray](#)" in "Installing Drives").
6. Connect the system to its electrical outlet and turn on the system, including any attached peripherals.
7. Run the IDE devices tests in the system diagnostics to determine whether the CD drive works correctly.

If the tests failed, continue to step 8.

8. Turn off the system, including any attached peripherals, and disconnect the system from its electrical outlet.
9. Remove the back cover (see "[Removing the Back Cover](#)").
10. Remove the front cover (see "[Removing the Front Cover](#)").
11. Ensure that the CD/diskette drive interface cable is securely connected to the interposer board on the CD/diskette drive assembly and to the peripheral riser card.
12. Ensure that the peripheral riser card is properly installed (see "[Replacing the Peripheral Riser Card](#)" in "Installing System Options").
13. Replace the front cover (see "[Replacing the Front Cover](#)").
14. Replace the back cover (see "[Replacing the Back Cover](#)").
15. Connect the system to its electrical outlet and turn on the system, including any attached peripherals.
16. Run the IDE devices tests in the system diagnostics to determine whether the CD drive works correctly.

If the problem is not resolved, see "[Getting Help](#)" for instructions on obtaining technical assistance.

---

## Troubleshooting SCSI Tape Drives

### Problem

- 1 Defective tape drive
- 1 Defective tape cartridge
- 1 Software or device driver
- 1 Defective I/O riser card

### Action

1. Remove the tape that was in use when the problem occurred and replace it with a tape that you know is not defective.
2. Verify that any required SCSI device drivers are installed on the hard drive and are configured correctly.

For instructions on installing and configuring device drivers for the system's integrated SCSI host adapter, see "Using the Dell OpenManage Server Assistant CD" in the *User's Guide*.

3. Reinstall the tape-backup software as instructed in the tape-backup software documentation.
4. Check the cable connections to the tape drive.
  - 1 For internal tape drives, perform the following steps:
    - a. Turn off the system, including any attached peripherals, and disconnect the system from its electrical outlet.
    - b. Check the SCSI cable connection from the tape drive to the I/O riser card.
    - c. Check the DC power cable connection to the tape drive.
  - 1 For external tape drives, perform the following steps:
    - a. Turn off the system, including any attached peripherals, and disconnect the system from its electrical outlet.
    - b. Check the SCSI cable connection from the tape drive to the external SCSI connector on the back panel.
    - c. Check the SCSI cable connection from the external SCSI connector on the back panel to the I/O riser card.
    - d. Check the AC power cable connection to the tape drive.
5. Verify that the tape drive is configured for a unique SCSI ID number and that the tape drive is terminated or not terminated as appropriate.

See the documentation for the tape drive for instructions on selecting the SCSI ID and enabling or disabling termination.

6. Reconnect the system to the electrical outlet and turn on the system.
  7. If the problem is not resolved, see "[Getting Help](#)" for instructions on obtaining technical assistance.
- 

## Troubleshooting Hard Drives

### Problem

- 1 Faulty hard drive
- 1 Faulty SCSI backplane board
- 1 Faulty or loose SCSI cable connections to a RAID controller card

#### Action

 **NOTICE:** This troubleshooting procedure can destroy data stored on the hard drive. Before you proceed, back up all the files on the hard drive.

1. Reboot your system and enter the SCSI configuration utility by pressing <Ctrl><h>, <Ctrl><a>, or <Ctrl><m>, depending on the controller.
2. Check that the primary SCSI channel is enabled, and reboot the system.

See the documentation supplied with the controller for information on the configuration utility.

3. Verify that the device drivers are installed and configured correctly.

See the operating system's documentation.

 **NOTE:** If a drive shows signs of imminent failure, the status indicator blinks green, then amber, and off, repeating this sequence every two seconds. If a drive has failed, the status indicator blinks amber four times per second.

4. Remove the faulty hard drive and install it in the another drive bay.
5. If the problem is resolved, reinstall the hard drive in the original bay.

If the hard drive functions properly in the original bay, the drive carrier could have intermittent problems. Replace the hard drive (see "[Installing a SCSI Hard Drive](#)").

If the hard drive still does not function properly in the original bay, the SCSI backplane board has a defective connector. See "[Getting Help](#)" for instructions on obtaining technical assistance.

6. Check the SCSI cable connections inside the system:
  - a. Turn off the system, including any attached peripherals, and disconnect the system from its electrical outlet.
  - b. Remove the front cover (see "[Removing the Front Cover](#)").
  - c. Check the SCSI cable connection to the RAID controller card.

 **NOTE:** To operate the SCSI backplane in a 1 x 8 configuration, make sure that the SCSI cable is connected to the Channel A connector on the SCSI backplane's daughter card. To operate the SCSI backplane in a 2 x 4 configuration, make sure that both SCSI cables are connected to the daughter card.

7. Partition and logically format the hard drive. If possible, restore the files to the drive.

To partition and logically format the drive, see the operating system documentation.

If the problem is not resolved, see "[Getting Help](#)."

---

## Troubleshooting a RAID Controller Card

Your system may contain an optional RAID controller card. If you encounter problems with the controller, see the RAID controller's documentation for detailed information on troubleshooting.

---

[Back to Contents Page](#)



[Back to Contents Page](#)

## Installing System Options

Dell™ PowerEdge™ 6600 Systems Installation and Troubleshooting Guide

- [Fan Assembly Tray](#)
- [Power Supplies](#)
- [AC Power Module](#)
- [Expansion Cards](#)
- [Peripheral Riser Card](#)
- [I/O Riser Card](#)
- [Memory Riser Cards](#)
- [Memory Modules](#)
- [Microprocessor Tray](#)
- [Microprocessors](#)
- [System Battery](#)

This section describes how to install the following options:

- 1 Expansion cards
- 1 Memory upgrades
- 1 Microprocessor upgrades

This section also includes instructions for replacing:

- 1 Fans
- 1 I/O riser card
- 1 Peripheral riser card
- 1 Power supplies
- 1 System battery

---

### Fan Assembly Tray

The system includes a fan assembly tray containing six fans. The fans can be removed as an assembly or individually.

**CAUTION:** Before you perform these procedures, you must turn off the system and disconnect it from its power source. For more information, see "[Safety First—For You and Your System](#)" in "Troubleshooting Your System."

#### Removing the Fan Assembly Tray

1. Remove the back cover (see "[Removing the Back Cover](#)" in "Troubleshooting Your System").
2. Remove the front cover (see "[Removing the Front Cover](#)" in "Troubleshooting Your System").
3. Using the fan assembly tray handles, lift the assembly straight up to clear the chassis (see [Figure 6-1](#)).

#### Replacing the Fan Assembly Tray

**NOTICE:** Ensure that the memory riser card handles and the peripheral riser card handles are in the closed position before installing the fan assembly tray.

1. Align the alignment tabs with the slots in the chassis (see [Figure 6-1](#)).
2. Lower the fan assembly tray into the chassis.
3. Ensure that the fans are fully seated.
4. Replace the front cover (see "[Replacing the Front Cover](#)" in "Troubleshooting Your System").
5. Replace the back cover (see "[Replacing the Back Cover](#)" in "Troubleshooting Your System").

**Figure 6-1. Removing the Fan Assembly Tray**

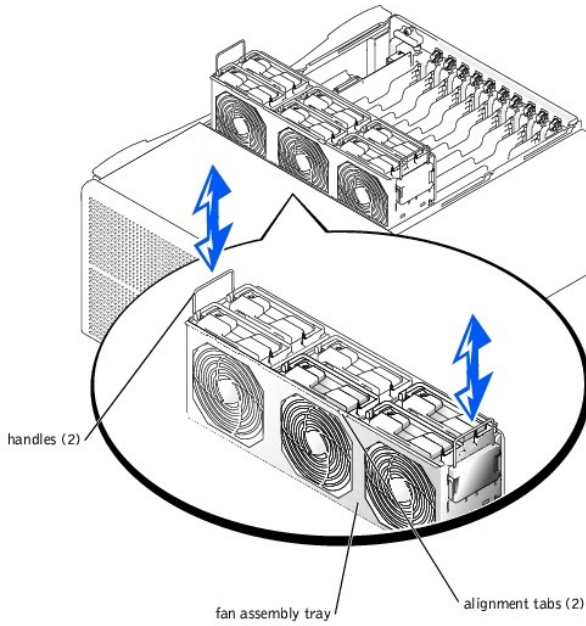

## Removing a Cooling Fan

**NOTE:** The procedure for removing each individual fan is the same.

1. Loosen the thumbscrew that secures the back cover to the chassis (see "[Removing the Back Cover](#)" in "Troubleshooting Your System").
2. Slide the back cover backward to the service position.

The back cover service position allows you to remove and replace fans without removing the back cover.

**NOTE:** The cooling fans are hot-pluggable. To maintain proper cooling while the system is on, replace only one fan at a time.

3. Locate the faulty fan.
4. Rotate the handle to the upright position and lift the fan straight up to clear the fan assembly (see [Figure 6-2](#)).

Figure 6-2. Removing and Replacing a Cooling Fan

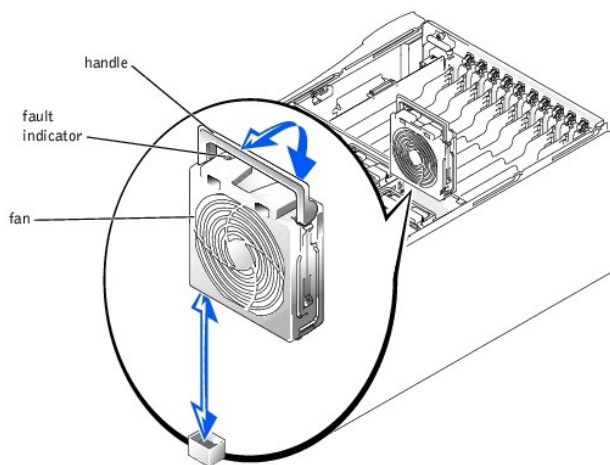

## Replacing a Cooling Fan

**NOTE:** The procedure for replacing each individual fan is the same.

**NOTE:** Ensure that the memory riser card handles and the peripheral riser card handles are in the closed position before installing a cooling fan.

1. Lower the fan into the fan assembly until the fan snaps into position (see [Figure 6-2](#)).
  2. Rotate the handle down into the installed position.
  3. Slide the back cover forward.
  4. Tighten the thumbscrew that secures the back cover to the chassis (see "[Replacing the Back Cover](#)" in "Troubleshooting Your System").
- 

## Power Supplies

The system includes three hot-pluggable power supplies.

### Removing a Power Supply

1. Squeeze the power-supply handle's release tab and rotate the handle down (see [Figure 6-3](#)).

**NOTICE:** The power supplies are hot-pluggable. The system requires two power supplies to be installed for the system to operate normally. The system is in the redundant mode when all three power supplies are installed. Remove and replace only one power supply at a time in a system that is powered on.

2. Remove the power supply by pulling the power supply straight out to clear the chassis (see [Figure 6-3](#)).

Figure 6-3. Removing and Replacing Power Supplies

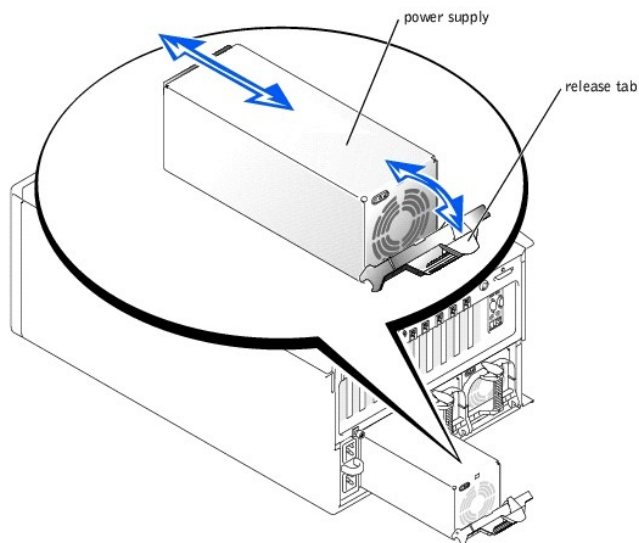

### Replacing a Power Supply

1. Slide the new power supply into the chassis (see [Figure 6-3](#)).
  2. Rotate the power supply handle up until it snaps into place, securing the power supply to the chassis.
- 

## AC Power Module

Your system can operate with an AC module or an integrated redundant AC power module. The AC module is used when a redundant AC power source is not required. The integrated redundant AC power module enables your system to use two AC inputs. Your system can operate on either of these inputs and automatically switches from a failing AC power source. Both of these modules are removed and replaced using the same procedure.

### Removing the AC Power Module

1. Turn off the system, including any attached peripherals, and disconnect the system from the electrical outlet.
2. Loosen the thumbscrew that secures the AC power module to the chassis.
3. Remove the AC power module by grasping the handle and pulling the module straight out to clear the chassis (see [Figure 6-4](#)).

Figure 6-4. Removing and Replacing the AC Power Module

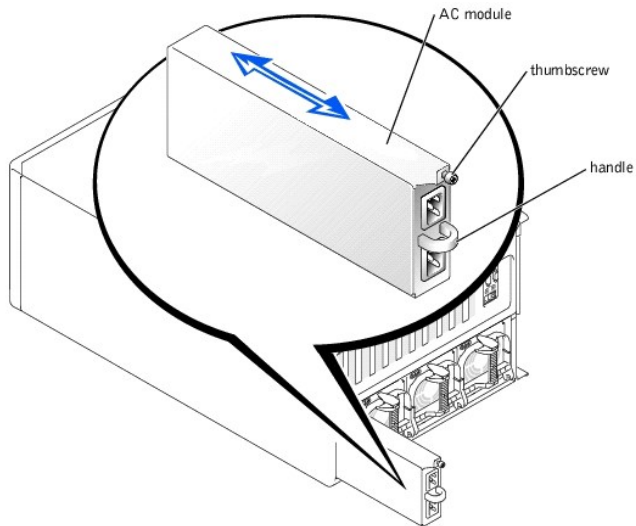

## Replacing the AC Power Module

1. Replace the AC power module by sliding the module into the chassis (see [Figure 6-4](#)).
2. Tighten the thumbscrew that secures the AC power module to the chassis.
3. Connect the system to the electrical outlet and turn on the system, including any attached peripherals.

## Expansion Cards

The system includes 11 hot-pluggable expansion slots. Slot 1 operates at 33 MHz. Slots 2 through 11 are capable of operating at 33, 66, or 100 MHz. The expansion slots are on six different PCI buses (see [Figure A-5](#) for expansion-slot buses and operating speeds).

### Expansion-Card Installation Guidelines

Use the following guideline when installing expansion cards:

- 1 If you are installing a remote access card, it must be installed in slot 1. Slot 1 operates at 33 MHz.
- 1 RAID controller cards for internal drives must be installed in expansion slots 2 or 3.
- 1 You can install expansion cards of different operating speeds on the same bus; however, all cards on the same bus will operate at the speed of the slowest card on that bus. For example, if one card on the bus has an operating speed of 66 MHz and the other card has an operating speed of 100 MHz, the bus will operate only at 66 MHz.
- 1 To optimize performance, install only one expansion card on a single PCI bus. Otherwise, install only cards of the same operating speed on the same PCI bus. To identify PCI buses, see [Figure A-3](#).
- 1 If you are replacing an expansion card with a card of a slower operating speed, you must power down the system to install the replacement card.
- 1 If the expansion card you are installing is of a slower operating speed than the cards already installed on the same PCI bus, you must power down all expansion slots on that bus. This action ensures that all expansion cards on that bus power up at the same operating speed. Otherwise, you can install the expansion card in an expansion slot that is alone on a PCI bus or on a PCI bus with cards of the same or slower operating speeds. To identify PCI buses, see [Figure A-3](#).
- 1 Certain operating systems support only "hot-replace," in which a hot-pluggable expansion card is replaced with its exact equivalent, using the same PCI resources.
- 1 If you are hot-plugging a NIC expansion card, you must either hot-plug the NIC card in an expansion slot that is alone on a PCI bus or on a PCI bus with no card other than another NIC. To identify PCI buses, see [Figure A-3](#).
- 1 If you have trouble hot-plugging a particular expansion card, turn off your system before installing the card. If the problem persists, see ["Getting Help"](#) for information on obtaining technical assistance.

### PCI Bus Scan Order

The system's BIOS scans and numbers PCI buses and devices during startup. Expansion slots are scanned according to the host bus ordering, not by the slot numbers. See [Table 6-1](#) for the order in which the expansion slots and embedded PCI devices are scanned. [Figure A-3](#) provides a diagram of the PCI buses and expansion slots.

Several additional factors affect the assignment of PCI bus numbers:

- 1 An expansion card may have its own PCI bridge chip, which requires the assignment of a bus number for the card as well as one for the bridge. A particular expansion card may have two PCI bridge chips, which would result in three sequential PCI bus numbers all assigned in the same expansion slot.
- 1 BIOS reserves PCI bus numbers that can be used when a hot-pluggable expansion card having its own PCI bridge chip is installed in the system.

If you install expansion cards, you may have some difficulty in directly determining the bus number of a controller on a particular expansion card. However, the PCI bus scan order listed in [Table 6-1](#) can help you determine the relative numbering of PCI buses within the expansion slots. For example, a PCI controller residing in expansion slot 3 will never have a lower bus number than one in slot 2 because slot 2 precedes slot 3 in the scan order.

**Table 6-1. PCI Bus Scan Order**

Order	Device or Slot
1	Integrated SCSI controller on the I/O riser card
2	Video
3	Expansion slot 1
4	Expansion slot 2
5	Expansion slot 3
6	NIC 1
7	NIC 2
8	Expansion slot 6
9	Expansion slot 7
10	Expansion slot 4
11	Expansion slot 5
12	Expansion slot 10
13	Expansion slot 11
14	Expansion slot 8
15	Expansion slot 9

**NOTE:** For the full name of an abbreviation or acronym used in this table, see "[Abbreviations and Acronyms](#)."

## Installing an Expansion Card

**CAUTION:** If your system's operating system does not support hot-plug PCI or PCI-X expansion cards or the expansion card itself does not support hot-plug installation, turn off the system, including any attached peripherals, and disconnect the system from its electrical outlet. For more information, see "[Safety First—For You and Your System](#)" in "Troubleshooting Your System."

**NOTE:** See "Protecting Against Electrostatic Discharge" in the safety instructions in your *System Information* document.

1. Remove the back cover (see "[Removing the Back Cover](#)" in "Troubleshooting Your System").

See the documentation that came with the expansion card for information on configuring the card, making internal connections, or otherwise customizing the card for your system.

2. Open the plastic expansion-card latch:
  - a. Press and hold the plastic tab on the outside of the system chassis.
  - b. Press the release tab on the latch inside the system chassis (see [Figure 6-5](#)).
  - c. Open the expansion-card latch and remove the filler bracket.
3. If your operating system does not support hot-plug expansion cards, turn off the system, including any attached peripherals, and disconnect the system from its electrical outlet.

If your operating system does support hot-plug expansion cards, press the expansion-slot notify button and wait until the status indicator turns green.

See "[Expansion-Slot Indicator Codes](#)" in "Indicators, Messages, and Codes" for information on expansion-slot status.

4. Install the expansion card (see [Figure 6-5](#)):
  - a. Position the expansion card so that the card-edge connector aligns with the expansion-card connector on the I/O board.
  - b. Insert the card-edge connector firmly into the expansion-card connector until the card is fully seated.

**Figure 6-5. Installing an Expansion Card**

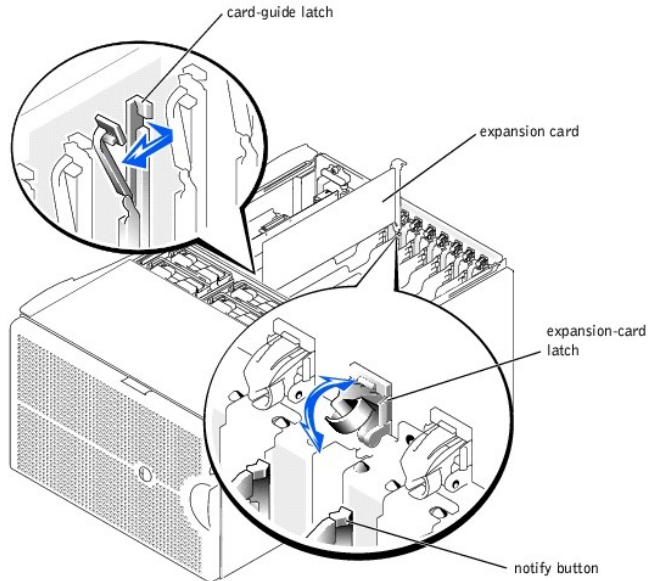

5. When the card is seated in the connector, close the expansion-card latch and the card-guide latch (see [Figure 6-5](#)).
6. Connect any cables that should be attached to the card.

See the documentation that came with the card for information about its cable connections.

- ☑ **NOTE:** SCSI cables connected from an expansion card to the SCSI backplane board should be routed under the fan assembly tray.
- ☑ **NOTE:** If the expansion card you are installing is of a slower operating speed than the cards already installed on the same PCI bus, you must power down all expansion slots on that bus. This action ensures that all expansion cards on that bus power up at the same operating speed.

7. Press the notify button for the expansion card that you installed and wait until the LED turns green.
8. Replace the back cover (see ["Replacing the Back Cover"](#) in "Troubleshooting Your System").

If you turned off your system in step 3 because your operating system does not support hot-plug expansion cards, replace the system back cover, reconnect the system to its electrical outlet, including any attached peripherals, and turn on the system.

## Removing an Expansion Card

**⚠ CAUTION:** If your system's operating system does not support hot-plug PCI or PCI-X expansion cards or the expansion card itself does not support hot-plug installation, turn off the system, including any attached peripherals, and disconnect the system from its electrical outlet. For more information, see ["Safety First—For You and Your System"](#) in "Troubleshooting Your System."

**🔧 NOTICE:** See "Protecting Against Electrostatic Discharge" in the safety instructions in your *System Information* document.

1. Remove the back cover (see ["Removing the Back Cover"](#) in "Troubleshooting Your System").
2. If your system's operating system does not support hot-plug expansion cards, turn off the system, including any attached peripherals, and disconnect the system from its electrical outlet.

If your operating system does support hot-plug expansion cards, press the notify button for the expansion slot and wait until the LED turns off.

3. Disconnect any cables connected to the card.
4. To release the expansion card:
  - a. Grasp the card-guide latch and pull it away from the chassis (see [Figure 6-5](#)).
  - b. Press and hold the plastic tab on the outside of the system chassis.
  - c. Press the release tab on the expansion-card latch inside the system (see [Figure 6-5](#)).
  - d. Open the expansion-card latch.
5. Grasp the expansion card by its top corners, and carefully remove it from the expansion-card connector.
6. If you are removing the card permanently, install a metal filler bracket over the empty card-slot opening.

- ☑ **NOTE:** You must install a filler bracket over an empty expansion slot to maintain Federal Communications Commission (FCC) certification of the system. The brackets also keep dust and dirt out of the system and aid in proper cooling and airflow inside the system.

7. Replace the back cover (see ["Replacing the Back Cover"](#) in "Troubleshooting Your System").

If you turned off your system in step 2 because your system's operating system does not support hot-plug expansion cards, replace the system back cover, reconnect the system to its electrical outlet, including any attached peripherals, and turn on the system.

---

## Peripheral Riser Card

The peripheral riser card provides the communication signals for the CD/diskette assembly and the control panel.

### Removing the Peripheral Riser Card

1. Turn off the system, including any attached peripherals, and disconnect the system from the electrical outlet.
2. Remove the back cover (see ["Removing the Back Cover"](#) in "Troubleshooting Your System").
3. Remove the front cover (see ["Removing the Front Cover"](#) in "Troubleshooting Your System").
4. Disconnect the following cables from the peripheral riser card (see [Figure 6-6](#)):
  - 1 The control panel cable from the CPCONN connector
  - 1 The CD/diskette drive cable from the CDFDCONN connector

**Figure 6-6. Removing and Replacing the Peripheral Riser Card**

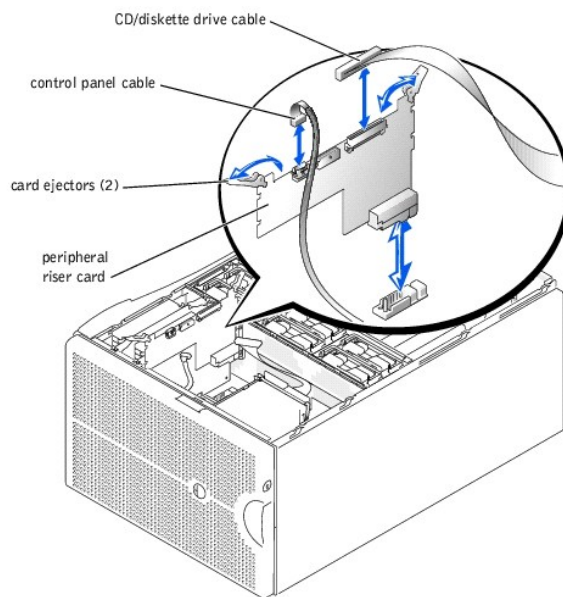

5. Grasp the peripheral riser card ejectors, and rotate the ejectors up to release the card from the microprocessor board (see [Figure 6-6](#)).
6. Lift the peripheral riser card straight up to clear the chassis.

### Replacing the Peripheral Riser Card

1. Position the peripheral riser card so that the card-edge connector is aligned with the riser card connector on the microprocessor board.
2. Lower the card into the chassis until the ejectors are in the peripheral riser card guides (see [Figure 6-6](#)).
3. Rotate the ejectors down until the card is fully seated.
4. Connect the following cables (see [Figure 6-6](#)):
  - 1 The control panel cable to the CPCONN connector
  - 1 The CD/diskette cable to the CDFDCONN connector
5. Replace the front cover (see ["Replacing the Front Cover"](#) in "Troubleshooting Your System").
6. Replace the back cover (see ["Replacing the Back Cover"](#) in "Troubleshooting Your System").

---

## I/O Riser Card

The I/O riser card provides the communication signals for an external SCSI device, the chassis intrusion switch, and the back-panel status indicator, as well as for external devices connected to the system back panel. The I/O riser card also contains the system configuration jumpers and the embedded server management processor.

## Removing the I/O Riser Card

1. Turn off the system, including any attached peripherals, and disconnect the system from the electrical outlet.
2. Remove the back cover (see ["Removing the Back Cover"](#) in "Troubleshooting Your System").
3. Disconnect the following I/O riser card cables (see [Figure 6-7](#)):
  - 1 The system status indicator cable
  - 1 The SCSI cable from the SCSI connector
  - 1 The chassis intrusion switch cable from the INTR connector

Figure 6-7. Removing and Replacing the I/O Riser Card

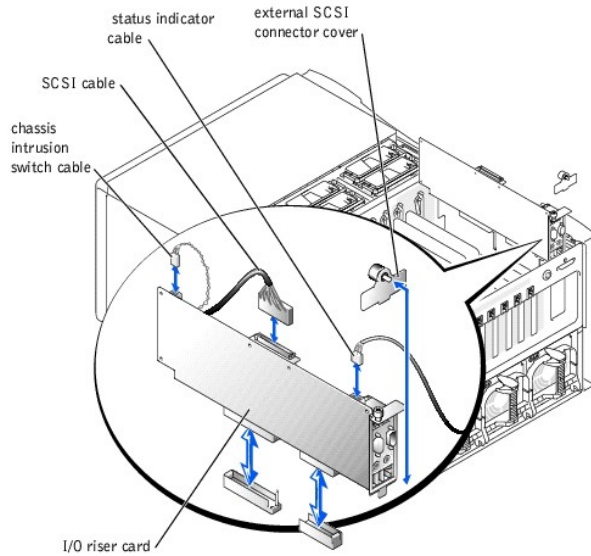

4. If applicable, loosen the thumbscrew that secures the external SCSI connector cover to the back panel and remove the cover (see [Figure 6-7](#)).
5. Loosen the thumbscrew that secures the I/O riser card to the back panel (see [Figure 6-7](#)).
6. Carefully lift the I/O riser card straight up to clear the chassis.

## Replacing the I/O Riser Card

1. Carefully lower the I/O riser card into the chassis while aligning the card-edge connectors with the connectors on the I/O board.
2. Insert the card firmly into the I/O board connector until the card is fully seated.
3. Tighten the thumbscrew that secures the I/O riser card to the back panel.
4. Replace the external SCSI connector cover and tighten the thumbscrew that secures the cover to the back panel.
5. Connect the following cables (see [Figure 6-7](#)):
  - 1 The back-panel status indicator cable
  - 1 The SCSI backplane cable to the SC5IA connector
  - 1 The intrusion switch cable to the INTR connector
6. Replace the back cover (see ["Replacing the Back Cover"](#) in "Troubleshooting Your System").

---

## Memory Riser Cards

The system contains two memory riser cards. Each card contains up to eight memory modules.

### Removing the Memory Riser Cards

**CAUTION:** Before you perform this procedure, you must turn off the system and disconnect it from its power source. For more information, see ["Safety First—For You and Your System"](#) in "Troubleshooting Your System."

**NOTICE:** See "Protecting Against Electrostatic Discharge" in the safety instructions in your *System Information* document.

1. Turn off the system, including any attached peripherals, and disconnect the system from the electrical outlet.



2. Remove the system front cover (see ["Removing the Front Cover"](#) in "Troubleshooting Your System").
3. Grasp the memory riser card ejectors, and rotate the ejectors up to release the card from the microprocessor board (see [Figure 6-8](#)).
4. Lift the memory riser card straight up to clear the chassis.

**Figure 6-8. Removing and Replacing Memory Riser Cards**

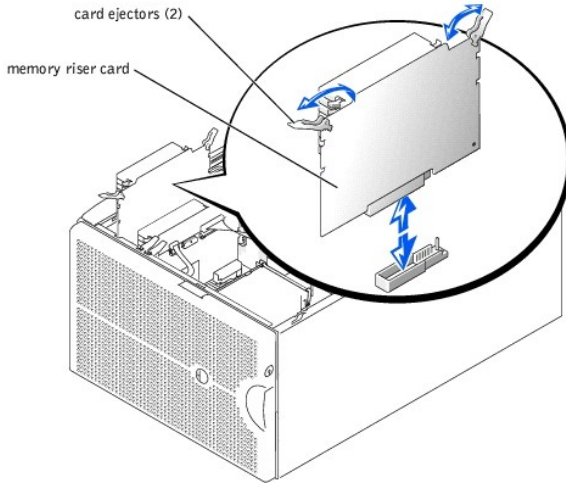

## Replacing the Memory Riser Cards

**NOTICE:** See "Protecting Against Electrostatic Discharge" in the safety instructions in your *System Information* document.

1. Position the memory riser card so that the card-edge connector is aligned with the riser card connector on the microprocessor board.
2. Lower the card into the chassis until the ejectors are in the memory riser card guides (see [Figure 6-8](#)).
3. Rotate the ejectors levers down until the card is fully seated.
4. Replace the system front cover (see ["Removing the Front Cover"](#) in "Troubleshooting Your System").

## Memory Modules

The memory modules are contained on two memory riser cards. Each riser card has eight memory module sockets. Between the two memory riser cards, the system can accommodate from 512 MB to 16 GB of registered memory. The memory module sockets on each riser card are arranged in pairs (A and B) on four banks (1-4). Memory modules must be installed in at least one bank on each memory riser card for the system to operate. The memory modules should be installed starting with bank 1 and ending with bank 4 (see [Figure 6-9](#)). Each bank on each memory riser card must contain the same memory module size. For example, if bank 1 on one riser card contains 128-MB memory modules, bank 1 on the other riser card must also contain 128-MB memory modules.

To obtain the desired total memory for your system, you may need to install memory modules of different sizes. This is supported as long as the memory modules installed in each bank are the same size. For example, if you wanted the total memory in your system to be 6 GB, each memory riser card configuration could be as follows:

**Table 6-2. Sample Memory Riser Card Configuration**

Memory Riser Card A	Memory Riser Card B
Bank 1 = 2 GB	Bank 1 = 2 GB
Bank 2 = 1 GB	Bank 2 = 1 GB

## Memory Upgrade Kits

The system is upgradable to 16 GB by installing combinations of 128-, 256-, 512-MB, and 1-GB registered memory modules. You can purchase memory upgrade kits as needed.

**NOTE:** The memory modules must be PC-1600 compliant.

## Memory Module Installation Guidelines

Memory module sockets are arranged in pairs, labeled A and B, on each memory riser card. A pair of sockets on each memory riser card forms a single memory bank. See [Figure 6-9](#) to identify the sockets on a memory riser card.

When you install memory modules, follow these guidelines:

- 1 Each bank must contain identical modules. You must install memory modules in matched sets of four, two in each memory riser card (see [Figure 6-9](#)).
- 1 Install identical memory modules in sockets A and B for bank 1 before installing modules in sockets for bank 2, and so on.
- 1 Memory banks must be populated sequentially, which means that there can be no empty banks between the first and last populated banks.

**Figure 6-9. Memory Module Sockets**

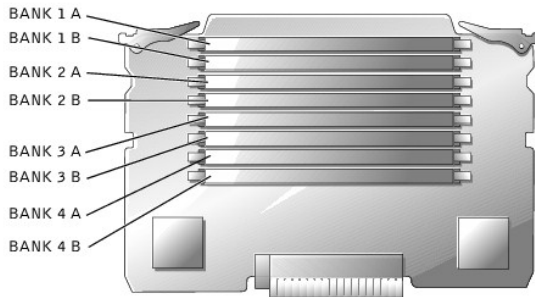

[Table 6-3](#) lists several sample memory configurations based on these guidelines.

**Table 6-3. Sample Memory Module Configurations**

Total Desired Memory	Bank 1		Bank 2		Bank 3		Bank 4	
	A	B	A	B	A	B	A	B
512 MB	128 MB	128 MB	None	None	None	None	None	None
1 GB	128 MB	128 MB	128 MB	128 MB	None	None	None	None
1 GB	256 MB	256 MB	None	None	None	None	None	None
2 GB	512 MB	512 MB	None	None	None	None	None	None
4 GB	512 MB	512 MB	512 MB	512 MB	None	None	None	None
4 GB	1 GB	1 GB	None	None	None	None	None	None
6 GB	1 GB	1 GB	512 MB	512 MB	None	None	None	None
12 GB	1 GB	1 GB	1 GB	1 GB	1 GB	1 GB	None	None
14 GB	1 GB	1 GB	1 GB	1 GB	1 GB	1 GB	512 MB	512 MB
16 GB	1 GB	1 GB	1 GB	1 GB	1 GB	1 GB	1 GB	1 GB

**NOTE:** This table is a sample configuration of just one memory riser card. For the total desired memory, you must configure both riser cards identically with the same memory module sizes.

## Performing a Memory Upgrade

**CAUTION:** Before you perform this procedure, you must turn off the system and disconnect it from its power source. For more information, see "[Safety First—For You and Your System](#)" in "Troubleshooting Your System."

**NOTICE:** See "Protecting Against Electrostatic Discharge" in the safety instructions in your *System Information* document.

1. Remove the memory riser cards (see "[Removing the Memory Riser Cards](#)").
2. Install or replace the memory module pairs on each memory riser card as necessary to reach the desired memory total (see "[Installing Memory Modules](#)" and "[Removing Memory Modules](#)").

See [Figure 6-9](#) for the memory module socket locations on each memory riser card.

3. Replace the memory riser cards (see "[Replacing the Memory Riser Cards](#)").
4. Reconnect the system to the electrical outlet, and turn on the system.

After the system completes the POST routine, it runs a memory test.

The system detects that the new memory does not match the system configuration information, which is stored in NVRAM. The monitor displays an error message that ends with the following words:

Press <F1> to continue; <F2> to enter System Setup

5. Press <F2> to enter the System Setup program, and check the **System Memory** setting in the system data box.

The system should have already changed the value in the **System Memory** setting to reflect the newly installed memory.

6. If the **System Memory** value is incorrect, one or more of the memory modules may not be installed properly. Repeat steps 1 through 4 again, checking

to make sure that the memory modules are firmly seated in their sockets.

7. Run the system memory test in the system diagnostics.

## Installing Memory Modules

**⚠ CAUTION:** Before you perform this procedure, you must turn off the system and disconnect it from its power source. For more information, see "[Safety First—For You and Your System](#)" in "Troubleshooting Your System."

**🔒 NOTICE:** See "Protecting Against Electrostatic Discharge" in the safety instructions in your *System Information* document.

1. Remove the memory riser cards (see "[Removing the Memory Riser Cards](#)").
2. Locate the memory module sockets on each memory riser card in which you will install a memory module (see [Figure 6-9](#)).
3. Press down and outward on the ejectors, as shown in [Figure 6-10](#), to allow the memory module to be inserted into the socket.

Figure 6-10. Removing and Replacing Memory Modules

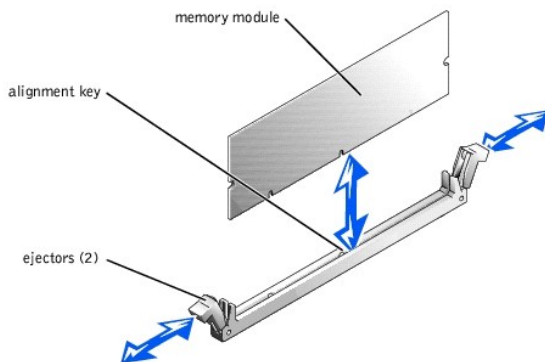

4. Align the memory module's edge connector with the alignment key, and insert the memory module in the socket (see [Figure 6-10](#)).

The memory module socket has an alignment key that allows the memory module to be installed in the socket in only one way.

5. Press down on the memory module with your thumbs while pulling up on the ejectors with your index fingers to lock the memory module into the socket (see [Figure 6-10](#)).

When the memory module is properly seated in the socket, the memory module socket ejectors align with the ejectors on the other sockets with memory modules installed.

6. Repeat steps 2 through 5 of this procedure to install the remaining memory modules.
7. Perform steps 3 through 7 of the procedure in "[Performing a Memory Upgrade](#)."

## Removing Memory Modules

**⚠ CAUTION:** Before you perform this procedure, you must turn off the system and disconnect it from its power source. For more information, see "[Safety First—For You and Your System](#)" in "Troubleshooting Your System."

**🔒 NOTICE:** See "Protecting Against Electrostatic Discharge" in the safety instructions in your *System Information* document.

1. Remove the memory riser cards (see "[Removing the Memory Riser Cards](#)").
2. Locate the memory module sockets on each memory riser card in which you will remove memory modules (see [Figure 6-9](#)).
3. Press down and outward on the ejectors until the memory module pops out of the socket (see [Figure 6-10](#)).

---

## Microprocessor Tray

The microprocessor tray must be removed to access the microprocessors and VRMs. The tray must also be removed to gain access to the SCSI backplanes. Use [Figure A-4](#) and [Table A-3](#) to locate the microprocessor board features.

### Removing the Microprocessor Tray

**⚠ CAUTION:** Before you perform this procedure, you must turn off the system and disconnect it from its power source. For more information, see "[Safety First—For You and Your System](#)" in "Troubleshooting Your System."

**🔒 NOTICE:** See "Protecting Against Electrostatic Discharge" in the safety instructions in your *System Information* document.

1. Open the bezel (see "[Opening the Bezel](#)" in "Troubleshooting Your System").
2. Turn off the system, including any attached peripherals, and disconnect the system from the electrical outlet.

3. Remove the back cover (see ["Removing the Back Cover"](#) in "Troubleshooting Your System").
4. Remove the front cover (see ["Removing the Front Cover"](#) in "Troubleshooting Your System").
5. Raise the following components to the service position:
  - 1 Memory riser cards (See ["Removing the Memory Riser Cards."](#))
  - 1 Peripheral riser card (See ["Removing the Peripheral Riser Card."](#))
6. Remove the fan assembly tray (see ["Removing the Fan Assembly Tray"](#)).
7. Rotate the microprocessor tray handles up until the tray is released from the front panel (see [Figure 6-11](#)).

**Figure 6-11. Removing and Replacing the Microprocessor Tray**

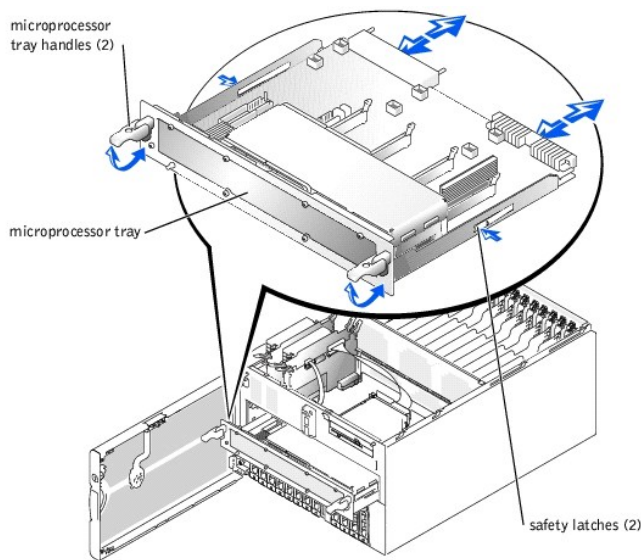

8. Slide the microprocessor tray out until the safety latches lock into place.
9. While pressing on the safety latches, pull the microprocessor tray straight out until the tray clears the chassis.

## Replacing the Microprocessor Tray

**NOTICE:** See "Protecting Against Electrostatic Discharge" in the safety instructions in your *System Information* document.

1. Slide the microprocessor tray into the chassis until the tray stops.
2. Lift the microprocessor tray handles up and push the tray forward slightly to engage the handle clasps.
3. Rotate the microprocessor tray handles down until the tray is secured to the front panel (see [Figure 6-11](#)).
4. Reseat the following components:
  - 1 Peripheral riser card (See ["Replacing the Peripheral Riser Card."](#))
  - 1 Memory riser cards (See ["Replacing the Memory Riser Cards."](#))
5. Replace the fan assembly tray (see ["Replacing the Fan Assembly Tray"](#)).
6. Replace the front cover (see ["Replacing the Front Cover"](#) in "Troubleshooting Your System").
7. Replace the back cover (see ["Replacing the Back Cover"](#) in "Troubleshooting Your System").
8. Close the bezel (see ["Closing the Bezel"](#) in "Troubleshooting Your System").

## Microprocessors

To take advantage of future options in speed and functionality, you can add additional microprocessors or replace installed microprocessors.

**NOTICE:** The additional microprocessors must be of the same type as the primary microprocessor. All microprocessors must also have the same L2 and L3 cache sizes.

Each microprocessor and its associated cache memory are contained in a PGA package that is installed in a ZIF socket on the microprocessor board.

In a single-microprocessor system, the microprocessor must be installed in the CPU1 socket.

 **NOTE:** A microprocessor and VRM must be installed in the CPU1 and VRM1 sockets, respectively. To identify CPU1 and VRM1 sockets, see [Figure A-4](#).

 **NOTICE:** If a microprocessor socket does not have a microprocessor installed, a heat sink blank must be installed for that socket.

The following items are included in the microprocessor upgrade kit:

- 1 A microprocessor
- 1 A heat sink
- 1 A VRM, if you are adding additional microprocessors

## Adding or Replacing a Microprocessor

 **CAUTION:** Before you perform this procedure, you must turn off the system and disconnect it from its power source. For more information, see "[Safety First—For You and Your System](#)" in "Troubleshooting Your System."

 **NOTICE:** See "Protecting Against Electrostatic Discharge" in the safety instructions in your *System Information* document.

1. Remove the microprocessor tray (see "[Removing the Microprocessor Tray](#)").
2. Place the microprocessor tray on a flat surface.
3. While holding the tab on the side release lever, rotate the lever up until the cover is released from the side of the enclosure (see [Figure 6-12](#)).

Figure 6-12. Removing and Replacing the Microprocessor Cover

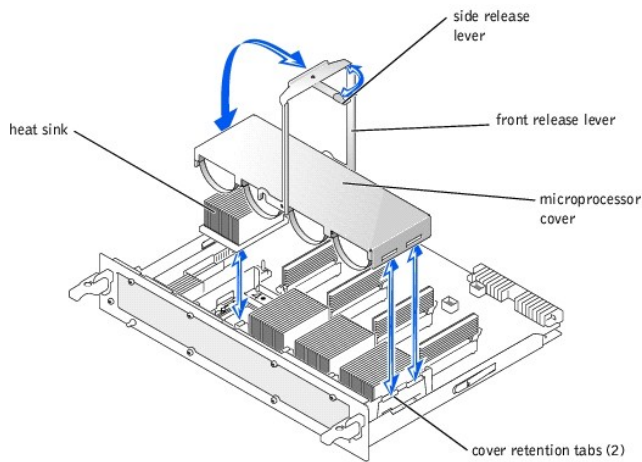

4. While holding the front release lever, rotate the lever up until the cover is released from the front of the enclosure (see [Figure 6-12](#)).
5. Remove the cover.

 **CAUTION:** The microprocessor and heat sink can become extremely hot. Be sure the microprocessor has had sufficient time to cool before handling.

 **NOTICE:** Never remove the heat sink from a microprocessor unless you intend to remove the microprocessor. The heat sink is necessary to maintain proper thermal conditions.

6. Remove the heat sink (see [Figure 6-12](#)).
7. Pull the socket release lever straight up until the microprocessor is released (see [Figure 6-13](#)).

Figure 6-13. Removing and Replacing the Microprocessor

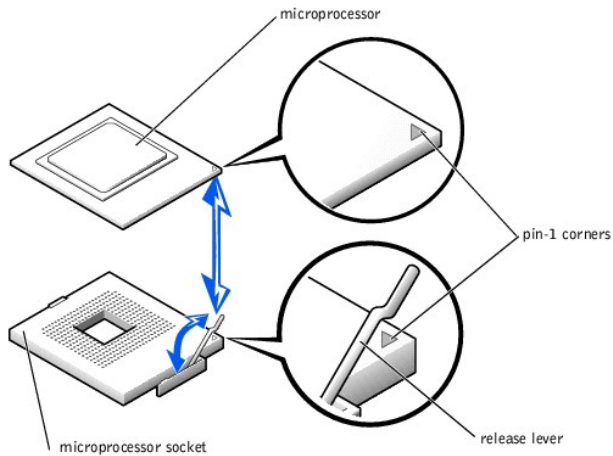

➡ **NOTICE:** Be careful not to bend any of the pins when removing the microprocessor. Bending the pins can permanently damage the microprocessor.

8. Lift the microprocessor out of the socket and leave the release lever up so that the socket is ready for the new microprocessor (see [Figure 6-13](#)).
9. Unpack the new microprocessor.

If any of the pins on the microprocessor appear bent, see "[Getting Help](#)" for instructions on obtaining technical assistance.

10. If the release lever on the microprocessor socket is not all the way up, move it to that position now.
11. Align the gold triangle on the microprocessor (see [Figure 6-13](#)) with the triangle on the microprocessor socket.

🔍 **NOTE:** Zero insertion force is needed to install the microprocessor. If the microprocessor is aligned correctly, it should drop into the microprocessor socket.

➡ **NOTICE:** Positioning the microprocessor incorrectly can permanently damage the microprocessor and the system when you turn on the system. When placing the microprocessor in the socket, be sure that all of the pins on the microprocessor go into the corresponding holes. Be careful not to bend the pins.

12. Install the microprocessor in the socket (see [Figure 6-13](#)).
13. When the microprocessor is fully seated in the socket, rotate the socket release lever back down until it snaps into place, securing the microprocessor.
14. Place the new heat sink on top of the microprocessor (see [Figure 6-12](#)).
15. Orient the microprocessor cover as shown in [Figure 6-12](#).
16. Hook the end of the cover over the retention tabs on the edge of the microprocessor enclosure (see [Figure 6-12](#)).
17. Swing the microprocessor cover down.
18. Rotate the side release lever down to secure the cover to the side of the microprocessor enclosure (see [Figure 6-12](#)).
19. Rotate the front release lever down to secure the cover to the front of the microprocessor enclosure (see [Figure 6-12](#)).
20. If you are adding additional microprocessors, install the VRM in the corresponding VRM socket, pushing down firmly to make sure that the ejectors engage (see [Figure 6-14](#)).

**Figure 6-14. Installing the VRM**

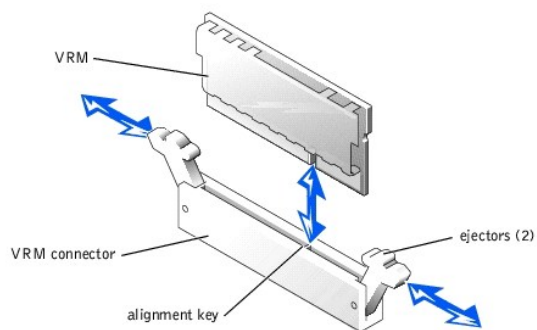

21. Replace the microprocessor tray (see "[Replacing the Microprocessor Tray](#)").
22. Reconnect your system and peripherals to their electrical outlets, and turn on the system.

As the system boots, it detects the presence of the new microprocessor(s) and automatically changes the system configuration information in the

System Setup program and displays the microprocessor ID number, operating speed, processor bus, and cache information.

23. Press <F2> to enter the System Setup program, and check that the microprocessor categories match the new system configuration (see "Using the System Setup Program" in your *User's Guide*).
24. Run the system diagnostics to verify that the new microprocessor is operating correctly.

See "[Running the System Diagnostics](#)" for information on running the diagnostics and troubleshooting any problems that may occur.

---

## System Battery

The system battery is a 3.0-volt (V), coin-cell battery. To replace the battery, perform the following steps.

**⚠ CAUTION:** Before you perform this procedure, you must turn off the system and disconnect it from its power source. For more information, see "[Safety First—For You and Your System](#)" in "Troubleshooting Your System."

**⚠ CAUTION:** There is a danger of a new battery exploding if it is incorrectly installed. Replace the battery only with the same or equivalent type recommended by the manufacturer. Discard used batteries according to the manufacturer's instructions.

1. Enter the System Setup program and, if possible, make a printed copy of the System Setup screens (see "Using the System Setup Program" in the *User's Guide*).
2. Turn off the system, including any attached peripherals, and disconnect the system from the electrical outlet.

**👉 NOTICE:** See "Protecting Against Electrostatic Discharge" in the safety instructions in your *System Information* document.

3. Remove the back cover (see "[Removing the Back Cover](#)" in "Troubleshooting Your System").
4. Remove the I/O riser card (see "[Removing the I/O Riser Card](#)").
5. Remove the system battery (see [Figure A-2](#)).

You can pry the system battery out of its socket with your fingers or with a blunt, nonconductive object such as a plastic screwdriver.

6. Install the new system battery with the side labeled "+" facing up (see [Figure 6-15](#)).

**Figure 6-15. Installing the System Battery**

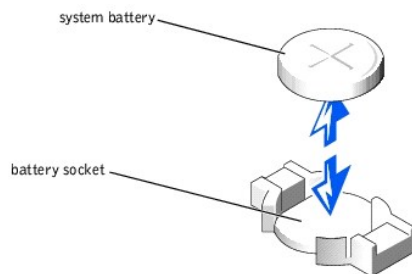

7. Replace the I/O riser card (see "[Replacing the I/O Riser Card](#)").
8. Replace the back cover (see "[Replacing the Back Cover](#)" in "Troubleshooting Your System.>").
9. Reconnect the system and any attached peripherals to their electrical outlets and turn them on.
10. Enter the System Setup program to confirm that the battery is operating properly (see "Using the System Setup Program" in the *User's Guide*).
11. Enter the correct time and date in the System Setup program's **Time** and **Date** settings.
12. Re-enter any system configuration information that is no longer displayed on the System Setup screens, and then exit the System Setup program.
13. To test the newly installed battery, power down and disconnect the system from its electrical source for at least an hour.
14. After an hour, connect the system to its electrical source and turn on the system.
15. Enter the System Setup program and if the time and date are still incorrect, see "[Getting Help](#)" for instructions on obtaining technical assistance.

[Back to Contents Page](#)

## Installing Drives

### Dell™ PowerEdge™ 6600 Systems Installation and Troubleshooting Guide

- [SCSI Interface Cables](#)
- [SCSI Configuration Information](#)
- [Peripheral Bay](#)
- [External SCSI Tape Drive](#)
- [SCSI Hard Drives](#)
- [CD and Diskette Drives](#)
- [Installing a RAID Controller Card](#)
- [Configuring the Boot Device](#)

Your system features a hard-drive bay that contains up to eight 1-inch SCSI hard drives. Your system also features a peripheral bay that can be used for an additional four 1-inch SCSI hard drives or an internal tape drive. A CD drive and a diskette drive are mounted together on a tray that slides in and out of the front panel and connects to a connector inside the system. This connector is cabled to the peripheral riser card. This allows the diskette and CD drives to be serviced without removing system covers or connecting and disconnecting cables. This section contains instructions for replacing these devices.

---

## SCSI Interface Cables

If you are installing a SCSI tape drive in the peripheral bay, you must connect it to the I/O riser card. If you are installing SCSI hard drives in the peripheral bay, you must connect the interface cable from the peripheral bay's daughter card to a RAID controller card.

These interface connectors are keyed for correct insertion. Keying ensures that the pin-1 wire in the cable connects to pin 1 in the connectors on both ends.

When you disconnect an interface cable, take care to grasp the cable connector, rather than the cable itself, to avoid stress on the cable.

---

## SCSI Configuration Information

Although SCSI devices are installed in essentially the same way as other devices, their configuration requirements are different. To configure a SCSI device installed in the peripheral bay, follow the guidelines in the following subsections.

### SCSI ID Numbers

Each device attached to a SCSI host adapter must have a unique SCSI ID number from 0 to 15.

A SCSI tape drive is configured as SCSI ID 6 (the default ID number for a tape drive).

 **NOTE:** There is no requirement that SCSI ID numbers be assigned sequentially or that devices be attached to the cable according to ID number.

### Device Termination

SCSI logic requires that the two devices at opposite ends of the SCSI chain be terminated and that all devices in between be unterminated. The SCSI cable included in the upgrade kit has an active terminator installed at the end of the cable. Therefore, when configuring the devices in the peripheral bay, you should disable the device's termination.

---

## Peripheral Bay

The peripheral bay can be used for an additional four 1-inch SCSI hard drives or a tape drive.

### Installing Hard Drives in the Peripheral Bay

Installing hard drives in the peripheral bay is identical to installing hard drives in the hard drive bay (see "[SCSI Hard Drives](#)" found later in this document).

### Installing Internal Tape Drives in the Peripheral Bay

Internal tape drives are connected directly to the I/O riser card.

 **CAUTION:** Before you perform this procedure, you must turn off the system and disconnect it from its power source. For more information, see "[Safety First—For You and Your System](#)" in "Troubleshooting Your System."

 **NOTICE:** See "Protecting Against Electrostatic Discharge" in the safety instructions in your *System Information* document.

1. Turn off the system, including any attached peripherals, and disconnect the system from the electrical outlet.
2. Remove the microprocessor tray (see "[Removing the Microprocessor Tray](#)" in "Installing System Board Options").
3. Remove the inserts from the front of the peripheral bay.



4. Slide the tape drive into the peripheral bay.
5. Connect the tape drive's power cable to the power distribution board and to the tape drive.
6. Connect the tape drive's interface cable to the tape drive and to the I/O riser card.
7. Check all cable connections that may have been loosened during this procedure.

Arrange the cables so that they will not catch on the system cover or block the airflow of the fans or cooling vents.

8. Replace the microprocessor tray (see "[Replacing the Microprocessor Tray](#)" in "Installing System Board Options").
  9. Reconnect the system and peripherals to their electrical outlets, and turn them on.
  10. Perform a tape backup and verification test with the drive as instructed in the tape-drive software documentation that came with the drive.
- 

## External SCSI Tape Drive

This subsection describes how to configure and install an external SCSI tape drive.

### Installing an External SCSI Tape Drive

 **NOTICE:** See "Protecting Against Electrostatic Discharge" in the safety instructions in your *System Information* document.

1. Turn off the system, including any attached peripherals, and disconnect the system from the electrical outlet.
2. Prepare the tape drive for installation.

Ground yourself by touching an unpainted metal surface on the back of the system, unpack the drive and controller card, and compare the jumper and switch settings with those in the drive documentation.

See "[SCSI Configuration Information](#)" for information on setting the drive's SCSI ID number and enabling termination (if required). Change any settings necessary for your system's configuration.

3. Connect the tape drive's interface cable to the external SCSI connector on the back of the system.
  4. Secure the connection by tightening the screws on the external SCSI connector.
  5. Reconnect the system and peripherals to electrical outlets, and turn them on.
  6. Perform a tape backup and verification test with the drive as instructed in the software documentation that came with the drive.
- 

## SCSI Hard Drives

This subsection describes how to install and configure SCSI hard drives in the system's internal hard-drive bays.

The internal hard-drive bays provide space for up to eight 1-inch hard drives. These drives connect to a SCSI backplane board. A SCSI cable connects the SCSI backplane board to the RAID controller card.

### Before You Begin

Before attempting to remove or install a drive while the system is running, see the documentation for the RAID controller card to ensure that the card is configured correctly to support hot-pluggable drive removal and insertion.

SCSI hard drives are supplied in special drive carriers that fit in the hard-drive bays.

 **NOTE:** You should use only drives that have been tested and approved for use with the SCSI backplane board.

You may need to use different programs than those provided with the operating system to partition and format SCSI hard drives. See "Installing and Configuring SCSI Drivers" in the *User's Guide* for information and instructions.

 **NOTICE:** Do not turn off or reboot your system while the drive is being formatted. Doing so can cause a drive failure.

When you format a high-capacity SCSI hard drive, allow enough time for the formatting to be completed. Long format times for these drives are normal. A 9-GB hard drive, for example, can take up to 2.5 hours to format.

### Installing a SCSI Hard Drive

 **NOTICE:** Not all operating systems support hot-plug drive installation. See the documentation supplied with your operating system.

1. Power down the hard-drive bay.
2. Open the front bezel (see "[Opening the Bezel](#)" in "Troubleshooting Your System").
3. Open the hard-drive handle (see [Figure 7-1](#)).

**Figure 7-1. Installing a SCSI Hard Drive**

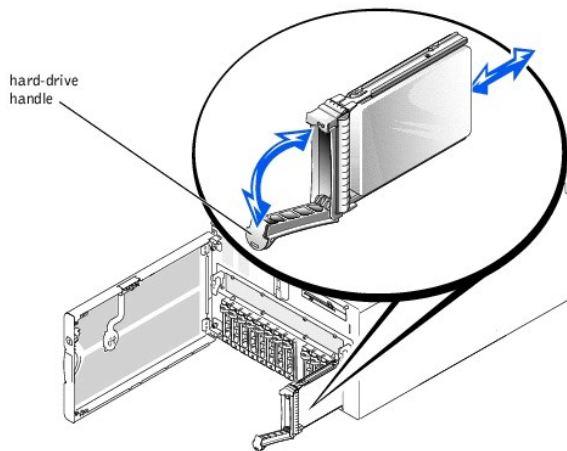

➔ **NOTICE:** Do not insert a hard-drive carrier and attempt to lock its handle next to a partially installed carrier. Doing so can damage the partially installed carrier's shield spring and make it unusable. Ensure that the adjacent drive carrier is fully installed.

4. Insert the hard drive into the drive bay (see [Figure 7-1](#)).
5. Close the hard-drive handle to lock it in place.
6. Close the front bezel (see "[Closing the Bezel](#)" in "Troubleshooting Your System").
7. Install any required SCSI device drivers (see "Installing and Configuring SCSI Drivers" in the *User's Guide* for information).
8. If the hard drive is new, run the **SCSI Controllers** test in the system diagnostics.

## Removing a SCSI Hard Drive

➔ **NOTICE:** Not all operating systems support hot-plug drive installation. See the documentation supplied with your operating system.

1. Open the bezel (see "[Opening the Bezel](#)" in "Troubleshooting Your System").
2. Power down the hard-drive bay and wait until the SCSI hard-drive indicator codes on the drive carrier signal that the drive can be removed safely.  
  
If the drive has been online, the drive status indicator will blink green twice per second as the drive is powered down. When all indicators are off, the drive is ready for removal.
3. Open the hard-drive handle to release the drive (see [Figure 7-1](#)).
4. Slide the hard drive out until it is free of the drive bay (see [Figure 7-1](#)).  
  
If you are permanently removing the hard drive, install a blank insert.
5. Close the front bezel (see "[Closing the Bezel](#)" in "Troubleshooting Your System").

## CD and Diskette Drives

The CD and diskette drives are mounted together on a tray that slides in and out of the front panel and connects to an interposer board in the system.

### Removing the CD/Diskette Drive Tray

1. Open the bezel (see "[Opening the Bezel](#)" in "Troubleshooting Your System").
2. Turn off the system, including any attached peripherals, and disconnect the system from the electrical outlet.
3. Press the release tab on the CD/diskette drive tray to release the tray from the connector in the system (see [Figure 7-2](#)).
4. Remove the CD/diskette drive tray.

### Replacing the CD/Diskette Drive Tray

1. Align the CD/diskette drive tray with the opening in the front panel.
2. Slide the CD/diskette drive tray into the system until the tray snaps into place (see [Figure 7-2](#)).
3. Connect the system to an electrical outlet and turn the system on, including any attached peripherals.
4. Close the bezel (see "[Closing the Bezel](#)" in "Troubleshooting Your System").

Figure 7-2. Removing and Replacing the CD/Diskette Drive Tray

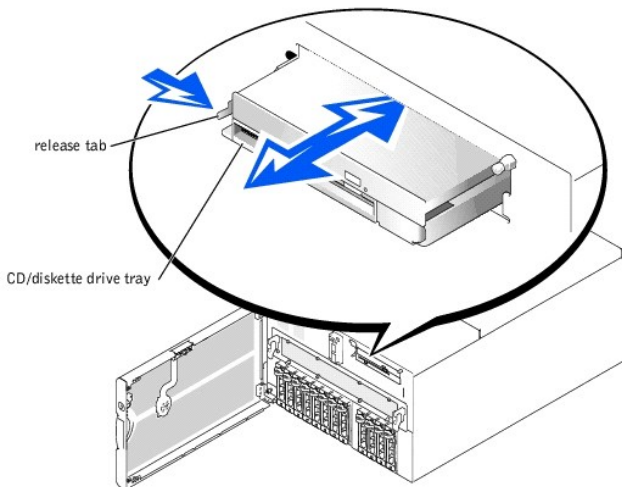

---

## Installing a RAID Controller Card

Follow these general guidelines when installing a RAID controller card. For specific instructions, see the documentation supplied with the controller card.

**⚠ CAUTION:** Before you perform this procedure, you must turn off the system and disconnect it from its power source. For more information, see ["Safety First—For You and Your System"](#) in ["Troubleshooting Your System."](#)

**🔍 NOTICE:** See "Protecting Against Electrostatic Discharge" in the safety instructions in your *System Information* document.

1. Unpack the RAID controller card, and prepare it for installation.

For instructions, see the documentation accompanying the card.

2. Remove the microprocessor tray (see ["Removing the Microprocessor Tray"](#) in ["Installing System Board Options"](#)).
3. Install the RAID controller card (see ["Installing an Expansion Card"](#) in ["Installing System Board Options"](#)).

If you are connecting the card to internal drives, install the RAID controller card in expansion slot 2 or 3.

4. Connect the SCSI interface cable as follows, routing it under the fan assembly tray:
  - 1 To operate the SCSI backplane in a 1 x 8 configuration, connect the interface cable to the SCSI A connector on the SCSI backplane board and to the RAID controller card.
  - 1 To operate the SCSI backplane in a 2 x 4 configuration, connect the interface cable to the SCSI B connector on the SCSI backplane board and to the RAID controller card.

To identify the correct RAID controller card connector, see the documentation for the card.

5. Replace the microprocessor tray (see ["Replacing the Microprocessor Tray"](#) in ["Installing System Board Options"](#)).
6. Reconnect the system to an electrical outlet and turn it on.
7. Install any required SCSI device drivers (see ["Installing and Configuring SCSI Drivers"](#) in the *User's Guide*).
8. Test the SCSI devices.

Test a SCSI hard drive by running the **SCSI Controllers** test in the system diagnostics.

---

## Configuring the Boot Device

If you plan to boot the system from a hard drive, the drive must be attached to the primary (or boot) controller. The device that the system boots from is determined by the boot order specified in the System Setup program.

The System Setup program provides options that the system uses to scan for installed boot devices. Refer to your system's *User's Guide* for information about the System Setup program.

---



[Back to Contents Page](#)

## Getting Help

### Dell™ PowerEdge™ 6600 Systems Installation and Troubleshooting Guide

- [Help Overview](#)
  - [Dell Contact Numbers](#)
- 

## Help Overview

This section describes the tools Dell provides to help you when you have a problem with your computer. It also tells you when and how to contact Dell for technical or customer assistance.

### Technical Assistance

If you need assistance with a technical problem, perform the following steps:

1. Complete the procedures in "[Troubleshooting Your System](#)."
2. Run the system diagnostics.
3. Make a copy of the Diagnostics Checklist, and fill it out.
4. Use Dell's extensive suite of online services available at the Dell | Support website ([support.dell.com](http://support.dell.com)) for help with installation and troubleshooting procedures.

For more information, see "[World Wide Web](#)."

5. If the preceding steps have not resolved the problem, call Dell for technical assistance.

When prompted by Dell's automated telephone system, enter your Express Service Code to route the call directly to the proper support personnel. If you do not have an Express Service Code, open the **Dell Accessories** folder, double-click the **Express Service Code** icon, and follow the directions.

 **NOTE:** Dell's Express Service Code system may not be available in all countries.

For instructions on using the technical support service, see "[Technical Support Service](#)" and "[Before You Call](#)."

## Help Tools

Dell provides a number of tools to assist you. These tools are described in the following sections.

 **NOTE:** Some of the following tools are not always available in all locations outside the continental U.S. Please call your local Dell representative for information on availability.

### World Wide Web

The Internet is your most powerful tool for obtaining information about your computer and other Dell products. Through the Internet, you can access most of the services described in this section, including AutoTech, TechFax, order status, technical support, and product information.

You can access Dell | Support at [support.dell.com](http://support.dell.com). Select your region on the **WELCOME TO DELL SUPPORT** page, and fill in the requested details to access help tools and information.

Dell can be accessed electronically using the following addresses:

- 1 World Wide Web

[www.dell.com/](http://www.dell.com/)

[www.dell.com/ap/](http://www.dell.com/ap/) (for Asian/Pacific countries only)

[www.euro.dell.com](http://www.euro.dell.com) (for Europe only)

[www.dell.com/la/](http://www.dell.com/la/) (for Latin American countries)

- 1 Anonymous file transfer protocol (FTP)

[ftp.dell.com/](ftp://ftp.dell.com/)

Log in as user:anonymous, and use your e-mail address as your password.

- 1 Electronic Support Service

[support@us.dell.com](mailto:support@us.dell.com)

[apsupport@dell.com](mailto:apsupport@dell.com) (for Asian/Pacific countries only)

[support.euro.dell.com](mailto:support.euro.dell.com) (for Europe only)

- 1 Electronic Quote Service

sales@dell.com

apmarketing@dell.com (for Asian/Pacific countries only)

- 1 Electronic Information Service

info@dell.com

## AutoTech Service

Dell's automated technical support service—AutoTech—provides recorded answers to the questions most frequently asked by Dell customers about their portable and desktop computer systems.

When you call AutoTech, you use your touch-tone telephone to select the subjects that correspond to your questions.

The AutoTech service is available 24 hours a day, seven days a week. You can also access this service through the technical support service. For the telephone number to call, see "[Dell Contact Numbers](#)."

## TechFax Service

Dell takes full advantage of fax technology to serve you better. Twenty-four hours a day, seven days a week, you can call the Dell TechFax line toll-free for all kinds of technical information.

Using a touch-tone phone, you can select from a full directory of topics. The technical information you request is sent within minutes to the fax number you designate. For the TechFax telephone number to call, see "[Dell Contact Numbers](#)."

## Automated Order-Status System

You can call this automated service to check on the status of any Dell products that you have ordered. A recording prompts you for the information needed to locate and report on your order. For the telephone number to call, see "[Dell Contact Numbers](#)."

## Technical Support Service

Dell's industry-leading hardware technical-support service is available 24 hours a day, seven days a week, to answer your questions about Dell hardware. Our technical support staff use computer-based diagnostics to provide fast, accurate answers to questions.

To contact Dell's technical support service, see "[Before You Call](#)" and then call the number for your country as listed in "[Dell Contact Numbers](#)."

## Problems With Your Order

If you have a problem with your order, such as missing parts, wrong parts, or incorrect billing, contact Dell for customer assistance. Have your invoice or packing slip handy when you call. For the telephone number to call, see "[Dell Contact Numbers](#)."

## Product Information

If you need information about additional products available from Dell, or if you would like to place an order, visit the Dell website at [www.dell.com/](http://www.dell.com/). For the telephone number to call to speak to a sales specialist, see "[Dell Contact Numbers](#)."

## Returning Items for Warranty Repair or Credit

Prepare all items being returned, whether for repair or credit, as follows:

1. Call Dell to obtain an authorization number, and write it clearly and prominently on the outside of the box.  
For the telephone number to call, see "[Dell Contact Numbers](#)."
2. Include a copy of the invoice and a letter describing the reason for the return.
3. Include a copy of the [Diagnostics Checklist](#) indicating the tests you have run and any error messages reported by the system diagnostics.
4. Include any accessories that belong with the item(s) being returned (such as power cables, software floppy disks, and guides) if the return is for credit.
5. Pack the equipment to be returned in the original (or equivalent) packing materials.

You are responsible for paying shipping expenses. You are also responsible for insuring any product returned, and you assume the risk of loss during shipment to Dell. Collect-on-delivery (C.O.D.) packages are not accepted.

Returns that are missing any of the preceding requirements will be refused at our receiving dock and returned to you.

## Before You Call

 **NOTE:** Have your Express Service Code ready when you call. The code helps Dell's automated-support telephone system direct your call more efficiently.

Remember to fill out the [Diagnostics Checklist](#). If possible, turn on your system before you call Dell for technical assistance and call from a telephone at or near the computer. You may be asked to type some commands at the keyboard, relay detailed information during operations, or try other troubleshooting steps possible only at the computer system itself. Make sure that the system documentation is available.

 **CAUTION:** Before servicing any components inside your computer, see "[Safety First—For You and Your System](#)."

Diagnostics Checklist	
Name: _____	Date: _____
Address: _____	Phone number: _____
Service tag (bar code on the back of the computer): _____	
Express Service Code: _____	
Return Material Authorization Number (if provided by Dell support technician): _____	
Operating system and version: _____	
Peripherals: _____	
_____	
_____	
Expansion cards: _____	
_____	
_____	
Are you connected to a network?    yes <input type="checkbox"/> no <input type="checkbox"/>	
Network, version, and network card: _____	
Programs and versions: _____	
_____	
_____	
See your operating system documentation to determine the contents of the system's startup files. Print each file if possible. Otherwise, record the contents of each file before calling Dell.	
Error message, beep code, or diagnostic code: _____	
Description of problem and troubleshooting procedures you performed: _____	
_____	
_____	
_____	

## Dell Contact Numbers

The following table provides country-specific access codes and telephone numbers, websites, and email addresses that you can use to contact Dell.

The codes required depend on where you are calling from as well as the destination of your call; in addition, each country has a different dialing protocol. If you need assistance in determining which codes to use, contact a local or an international operator.

 **NOTE:** Toll-free numbers are for use only within the country for which they are listed. Area codes are most often used to call long distance within your own country (not internationally)—in other words, when your call originates in the same country you are calling.

Country (City) International Access Code Country Code City Code	Department Name or Service Area, Website and E-Mail Address	Area Codes, Local Numbers, and Toll Free Numbers
<b>Antigua and Barbuda</b>	General Support	1-800-805-5924
<b>Argentina (Buenos Aires)</b>  International Access Code: 00  Country Code: 54  City Code: 11	Tech Support and Customer Care	toll free: 1-800-444-0733
	Sales	toll free: 1-800-444-3355
	Tech Support Fax	11 4515 7139
	Customer Care Fax	11 4515 7138
	Website: <a href="http://www.dell.com.ar">www.dell.com.ar</a>	
<b>Australia (Sydney)</b>  International Access Code: <b>0011</b>  Country Code: <b>61</b>  City Code: <b>2</b>	Home and Small Business	1-300-65-55-33
	Government and Business	toll free: 1-800-633-559
	Preferred Accounts Division (PAD)	toll free: 1-800-060-889
	Customer Care	toll free: 1-800-819-339
	Corporate Sales	toll free: 1-800-808-385
	Transaction Sales	toll free: 1-800-808-312
	Fax	toll free: 1-800-818-341
<b>Austria (Vienna)</b>  International Access Code:	Home/Small Business Sales	01 795 67602
	Home/Small Business Fax	01 795 67605

<b>900</b>	Home/Small Business Customer Care	01 795 67603
Country Code: <b>43</b>	Preferred Accounts/Corporate Customer Care	0660 8056
City Code: <b>1</b>	Home/Small Business Technical Support	01 795 67604
	Preferred Accounts/Corporate Technical Support	0660 8779
	Switchboard	01 491 04 0
	Website: <a href="http://support.euro.dell.com">support.euro.dell.com</a>	
	E-mail: <a href="mailto:tech_support_central_europe@dell.com">tech_support_central_europe@dell.com</a>	
<b>Barbados</b>	General Support	1-800-534-3066
<b>Belgium (Brussels)</b> International Access Code: <b>00</b> Country Code: <b>32</b> City Code: <b>2</b>	Technical Support	02 481 92 88
	Customer Care	02 481 91 19
	Home/Small Business Sales	toll free: 0800 16884
	Corporate Sales	02 481 91 00
	Fax	02 481 92 99
	Switchboard	02 481 91 00
	Website: <a href="http://support.euro.dell.com">support.euro.dell.com</a>	
	E-mail: <a href="mailto:tech_be@dell.com">tech_be@dell.com</a>	
	E-mail for French Speaking Customers: <a href="mailto:support.euro.dell.com/be/fr/emaildell/">support.euro.dell.com/be/fr/emaildell/</a>	
<b>Bermuda</b>	General Support	1-800-342-0671
<b>Brazil</b> International Access Code: <b>0021</b> Country Code: <b>55</b> City Code: <b>51</b>	Customer Support, Technical Support	0800 90 3355
	Tech Support Fax	51 481 5470
	Customer Care Fax	51 481 5480
	Sales	0800 90 3390
	Website: <a href="http://www.dell.com/br">www.dell.com/br</a>	
<b>Brunei</b> Country Code: <b>673</b>	Customer Technical Support (Penang, Malaysia)	604 633 4966
	Customer Service (Penang, Malaysia)	604 633 4949
	Transaction Sales (Penang, Malaysia)	604 633 4955
<b>Canada (North York, Ontario)</b> International Access Code: <b>011</b>	Automated Order-Status System	toll free: 1-800-433-9014
	AutoTech (Automated technical support)	toll free: 1-800-247-9362
	Customer Care (From outside Toronto)	toll free: 1-800-387-5759
	Customer Care (From within Toronto)	416 758-2400
	Customer Technical Support	toll free: 1-800-847-4096
	Sales (Direct sales—from outside Toronto)	toll free: 1-800-387-5752
	Sales (Direct sales—from within Toronto)	416 758-2200
	Sales (Federal government, education, and medical)	toll free: 1-800-567-7542
	Sales (Major accounts)	toll free: 1-800-387-5755
TechFax	toll free: 1-800-950-1329	
<b>Cayman Islands</b>	General Support	1-800-805-7541
<b>Chile (Santiago)</b> Country Code: <b>56</b> City Code: <b>2</b>	Sales, Customer Support, and Technical Support	toll free: 1230-020-4823
<b>China (Xiamen)</b> Country Code: <b>86</b> City Code: <b>592</b>	Home and Small Business Technical Support	toll free: 800 858 2437
	Corporate Accounts Technical Support	toll free: 800 858 2333
	Customer Experience	toll free: 800 858 2060
	Home and Small Business	toll free: 800 858 2222
	Preferred Accounts Division	toll free: 800 858 2062
	Large Corporate Accounts North	toll free: 800 858 2999
	Large Corporate Accounts East	toll free: 800 858 2020
	Large Corporate Accounts South	toll free: 800 858 2355
	Large Corporate Accounts GCP	toll free: 800 858 2055
	Large Corporate Accounts HK	toll free: 800 964108
	Large Corporate Accounts GCP HK	toll free: 800 907308
<b>Colombia</b>	General Support	980-9-15-3978
<b>Costa Rica</b>	General Support	0800-012-0435
<b>Czech Republic (Prague)</b> International Access Code: <b>00</b> Country Code: <b>420</b>	Technical Support	02 22 83 27 27
	Customer Care	02 22 83 27 11
	Fax	02 22 83 27 14
	TechFax	02 22 83 27 28



City Code: 2	Switchboard	02 22 83 27 11
	Website: <a href="http://support.euro.dell.com">support.euro.dell.com</a>	
	E-mail: <a href="mailto:czech_dell@dell.com">czech_dell@dell.com</a>	
<b>Denmark (Horsholm)</b> International Access Code: 00 Country Code: 45	Technical Support	45170182
	Relational Customer Care	45170184
	Home/Small Business Customer Care	32875505
	Switchboard	45170100
	Fax Technical Support (Upplands Vasby, Sweden)	46 0 859005594
	Fax Switchboard	45170117
	Website: <a href="http://support.euro.dell.com">support.euro.dell.com</a>	
	E-mail: <a href="mailto:den_support@dell.com">den_support@dell.com</a> E-mail Support for Servers: <a href="mailto:Nordic_server_support@dell.com">Nordic_server_support@dell.com</a>	
<b>Dominican Republic</b>	General Support	1-800-148-0530
<b>El Salvador</b>	General Support	01-899-753-0777
<b>Finland (Helsinki)</b> International Access Code: 990 Country Code: 358 City Code: 9	Technical Support	09 253 313 60
	Technical Support Fax	09 253 313 81
	Relational Customer Care	09 253 313 38
	Home/Small Business Customer Care	09 693 791 94
	Fax	09 253 313 99
	Switchboard	09 253 313 00
	Website: <a href="http://support.euro.dell.com">support.euro.dell.com</a>	
	E-mail: <a href="mailto:fin_support@dell.com">fin_support@dell.com</a>	
<b>France (Paris) (Montpellier)</b> International Access Code: 00 Country Code: 33 City Codes: (1) (4)	<b>Home and Small Business</b>	
	Technical Support	0825 387 270
	Customer Care	0825 823 833
	Switchboard	0825 004 700
	Switchboard (Alternative)	04 99 75 40 00
	Sales	0825 004 700
	Fax	0825 004 701
	Fax (Alternative)	04 99 75 40 01
	Website: <a href="http://support.euro.dell.com">support.euro.dell.com</a>	
	E-mail: <a href="mailto:support.euro.dell.com/fr/fr/emailldell/">support.euro.dell.com/fr/fr/emailldell/</a>	
	<b>Corporate</b>	
	Technical Support	0825 004 719
	Customer Care	0825 338 339
	Switchboard	01 55 94 71 00
	Sales	01 55 94 71 00
	Fax	01 55 94 71 01
	Website: <a href="http://support.euro.dell.com">support.euro.dell.com</a>	
	E-mail: <a href="mailto:support.euro.dell.com/fr/fr/emailldell/">support.euro.dell.com/fr/fr/emailldell/</a>	
<b>Germany (Langen)</b> International Access Code: 00 Country Code: 49 City Code: 6103	Technical Support	06103 766-7200
	Home/Small Business Customer Care	0180-5-224400
	Global Segment Customer Care	06103 766-9570
	Preferred Accounts Customer Care	06103 766-9420
	Large Accounts Customer Care	06103 766-9560
	Public Accounts Customer Care	06103 766-9555
	Switchboard	06103 766-7000
	Website: <a href="http://support.euro.dell.com">support.euro.dell.com</a> E-mail: <a href="mailto:tech_support_central_europe@dell.com">tech_support_central_europe@dell.com</a>	
<b>Guatemala</b>	General Support	1-800-999-0136
<b>Hong Kong</b> International Access Code: 001 Country Code: 852	Technical Support	toll free: 800 96 4107
	Customer Service (Penang, Malaysia)	604 633 4949
	Transaction Sales	toll free: 800 96 4109
	Corporate Sales	toll free: 800 96 4108
<b>India</b>	Technical Support	1600 33 8045
	Sales	1600 33 8044
<b>Ireland (Cherrywood)</b> International Access Code: 16	Technical Support	1850 543 543
	Home User Customer Care	01 204 4095

Country Code: <b>353</b> City Code: <b>1</b>	Small Business Customer Care	01 204 4026
	Corporate Customer Care	01 279 5011
	Sales	01 204 4444
	SalesFax	01 204 0144
	Fax	204 5960
	Switchboard	01 204 4444
	Website: <a href="http://support.euro.dell.com">support.euro.dell.com</a>	
	E-mail: <a href="mailto:dell_direct_support@dell.com">dell_direct_support@dell.com</a>	
<b>Italy (Milan)</b> International Access Code: <b>00</b> Country Code: <b>39</b> City Code: <b>02</b>	<b>Home and Small Business</b>	
	Technical Support	02 577 826 90
	Customer Care	02 696 821 14
	Fax	02 696 821 13
	Switchboard	02 696 821 12
	Website: <a href="http://support.euro.dell.com">support.euro.dell.com</a>	
	E-mail: <a href="mailto:support.euro.dell.com/it/it/emaildell/">support.euro.dell.com/it/it/emaildell/</a>	
	<b>Corporate</b>	
	Technical Support	02 577 826 90
	Customer Care	02 577 825 55
	Fax	02 575 035 30
	Switchboard	02 577 821
	Website: <a href="http://support.euro.dell.com">support.euro.dell.com</a>	
	E-mail: <a href="mailto:support.euro.dell.com/it/it/emaildell/">support.euro.dell.com/it/it/emaildell/</a>	
<b>Jamaica</b>	General Support	1-800-682-3639
<b>Japan (Kawasaki)</b> International Access Code: <b>001</b> Country Code: <b>81</b> City Code: <b>44</b>	Technical Support (Server)	toll free: 0120-1984-35
	Technical Support Outside of Japan (Server)	81-44-556-4152
	Technical Support (Dimension™ and Inspiron™)	toll free: 0120-1982-26
	Technical Support Outside of Japan (Dimension and Inspiron)	81-44-520-1435
	Technical Support (Dell Precision™, OptiPlex™, and Latitude™)	toll free: 0120-1984-33
	Technical Support Outside of Japan (Dell Precision, OptiPlex, and Latitude)	81-44-556-3894
	24-Hour Automated Order Service	044 556-3801
	Customer Care	044 556-4240
	Business Sales Division (Up to 400 employees)	044 556 3494
	Preferred Accounts Division Sales (Over 400 employees)	044 556-3433
	Large Corporate Accounts Sales (Over 3500 employees)	044 556-3440
	Public Sales (Government agencies, educational institutions, and medical institutions)	044 556 3440
	Global Segment Japan	044 556 3469
	Individual User	044 556 1657
	Faxbox Service	044 556-3490
	Switchboard	044 556-4300
Website: <a href="http://support.jp.dell.com">support.jp.dell.com</a>		
<b>Korea (Seoul)</b> International Access Code: <b>001</b> Country Code: <b>82</b> City Code: <b>2</b>	Technical Support	toll free: 080-200-3800
	Sales	toll free: 080-200-3600
	Customer Service (Seoul, Korea)	toll free: 080-200-3800
	Customer Service (Penang, Malaysia)	604 633 4949
	Fax	2194-6202
	Switchboard	2194-6000
<b>Latin America</b>	Customer Technical Support (Austin, Texas, U.S.A.)	512 728-4093
	Customer Service (Austin, Texas, U.S.A.)	512 728-3619
	Fax (Technical Support and Customer Service)(Austin, Texas, U.S.A.)	512 728-3883
	Sales (Austin, Texas, U.S.A.)	512 728-4397
	SalesFax (Austin, Texas, U.S.A.)	512 728-4600
		or 512 728-3772
<b>Luxembourg</b> International Access Code: <b>00</b> Country Code: <b>352</b>	Technical Support (Brussels, Belgium)	02 481 92 88
	Home/Small Business Sales (Brussels, Belgium)	toll free: 080016884
	Corporate Sales (Brussels, Belgium)	02 481 91 00
	Customer Care (Brussels, Belgium)	02 481 91 19
	Fax (Brussels, Belgium)	02 481 92 99
	Switchboard (Brussels, Belgium)	02 481 91 00

	Website: <a href="http://support.euro.dell.com">support.euro.dell.com</a>	
	E-mail: <a href="mailto:tech_be@dell.com">tech_be@dell.com</a>	
<b>Macau</b>	Technical Support	toll free: 0800 582
Country Code: <b>853</b>	Customer Service (Penang, Malaysia)	604 633 4949
	Transaction Sales	toll free: 0800 581
<b>Malaysia (Penang)</b>	Technical Support	toll free: 1 800 888 298
International Access Code: <b>00</b>	Customer Service	04 633 4949
Country Code: <b>60</b>	Transaction Sales	toll free: 1 800 888 202
City Code: <b>4</b>	Corporate Sales	toll free: 1 800 888 213
<b>Mexico</b>	Customer Technical Support	001-877-384-8979
International Access Code: <b>00</b>		or 001-877-269-3383
Country Code: <b>52</b>	Sales	50-81-8800
		or 01-800-888-3355
	Customer Service	001-877-384-8979
		or 001-877-269-3383
	Main	50-81-8800
		or 01-800-888-3355
<b>Netherlands Antilles</b>	General Support	001-800-882-1519
<b>Netherlands (Amsterdam)</b>	Technical Support	020 581 8838
International Access Code: <b>00</b>	Customer Care	020 581 8740
Country Code: <b>31</b>	Home/Small Business Sales	toll free: 0800-0663
City Code: <b>20</b>	Home/Small Business Sales Fax	020 682 7171
	Corporate Sales	020 581 8818
	Corporate Sales Fax	020 686 8003
	Fax	020 686 8003
	Switchboard	020 581 8818
	Website: <a href="http://support.euro.dell.com">support.euro.dell.com</a>	
	E-mail: <a href="mailto:tech_nl@dell.com">tech_nl@dell.com</a>	
<b>New Zealand</b>	Home and Small Business	0800 446 255
International Access Code: <b>00</b>	Government and Business	0800 444 617
Country Code: <b>64</b>	Sales	0800 441 567
	Fax	0800 441 566
<b>Nicaragua</b>	General Support	001-800-220-1006
<b>Norway (Lysaker)</b>	Technical Support	671 16882
International Access Code: <b>00</b>	Relational Customer Care	671 17514
Country Code: <b>47</b>	Home/Small Business Customer Care	23162298
	Switchboard	671 16800
	Fax Technical Support (Upplands Vasby, Sweden)	46 0 85 590 05 594
	Fax Switchboard	671 16865
	Website: <a href="http://support.euro.dell.com">support.euro.dell.com</a>	
	E-mail: <a href="mailto:nor_support@dell.com">nor_support@dell.com</a>	
	E-mail Support for Servers: <a href="mailto:Nordic_server_support@dell.com">Nordic_server_support@dell.com</a>	
<b>Panama</b>	General Support	001-800-507-0962
<b>Peru</b>	General Support	0800-50-669
<b>Poland (Warsaw)</b>	Customer Service Phone	57 95 700
International Access Code: <b>011</b>	Customer Care	57 95 999
Country Code: <b>48</b>	Sales	57 95 999
City Code: <b>22</b>	Customer Service Fax	57 95 806
	Reception Desk Fax	57 95 998
	Switchboard	57 95 999
	Website: <a href="http://support.euro.dell.com">support.euro.dell.com</a>	
	E-mail: <a href="mailto:pl_support@dell.com">pl_support@dell.com</a>	
<b>Portugal</b>	Technical Support	35 800 834 077
International Access Code: <b>00</b>	Customer Care	800 300 415 or 35 800 834 075
Country Code: <b>35</b>	Sales	800 300 410 or 800 300 411 or 800 300 412 or

		351 214 220 710
	Fax	35 121 424 01 12
	E-mail: support.euro.dell.com/es/es/emaildell/	
<b>Puerto Rico</b>	General Support	1-800-805-7545
<b>St. Lucia</b>	General Support	1-800-882-1521
<b>Singapore (Singapore)</b>	Technical Support	toll free: 800 6011 051
International Access Code: 005	Customer Service (Penang, Malaysia)	604 633 4949
	Transaction Sales	toll free: 800 6011 054
Country Code: 65	Corporate Sales	toll free: 800 6011 053
<b>South Africa (Johannesburg)</b>	Technical Support	011 709 7710
International Access Code: 09/091	Customer Care	011 709 7707
	Sales	011 709 7700
Country Code: 27	Fax	011 706 0495
	Switchboard	011 709 7700
City Code: 11	Website: support.euro.dell.com	
	E-mail: dell_za_support@dell.com	
<b>Southeast Asian and Pacific Countries</b>	Customer Technical Support, Customer Service, and Sales (Penang, Malaysia)	604 633 4810
<b>Spain (Madrid)</b>	<b>Home and Small Business</b>	
International Access Code: 00	Technical Support	902 100 130
	Customer Care	902 118 540
Country Code: 34	Sales	902 118 541
	Switchboard	902 118 541
City Code: 91	Fax	902 118 539
	Website: support.euro.dell.com	
	E-mail: support.euro.dell.com/es/es/emaildell/	
	<b>Corporate</b>	
	Technical Support	902 100 130
	Customer Care	902 118 546
	Switchboard	91 722 92 00
	Fax	91 722 95 83
	Website: support.euro.dell.com	
	E-mail: support.euro.dell.com/es/es/emaildell/	
<b>Sweden (Upplands Vasby)</b>	Technical Support	08 590 05 199
International Access Code: 00	Relational Customer Care	08 590 05 642
	Home/Small Business Customer Care	08 587 70 527
Country Code: 46	Fax Technical Support	08 590 05 594
	Sales	08 590 05 185
City Code: 8	Website: support.euro.dell.com	
	E-mail: swe_support@dell.com	
	E-mail Support for Latitude and Inspiron: Swe-nbk_kats@dell.com	
	E-mail Support for OptiPlex: Swe_kats@dell.com	
	E-mail Support for Servers: Nordic_server_support@dell.com	
<b>Switzerland (Geneva)</b>	Technical Support (Home and Small Business)	0844 811 411
International Access Code: 00	Technical Support (Corporate)	0844 822 844
	Customer Care (Home and Small Business)	0848 802 202
Country Code: 41	Customer Care (Corporate)	0848 821 721
	Fax	022 799 01 90
City Code: 22	Switchboard	022 799 01 01
	Website: support.euro.dell.com	
	E-mail: swisstech@dell.com	
	E-mail for French Speaking HSB and Corporate Customers: support.euro.dell.com/ch/fr/emaildell/	
<b>Taiwan</b>	Technical Support	toll free: 0080 60 1255
International Access Code: 002	Technical Support (Servers)	toll free: 0080 60 1256
	Transaction Sales	toll free: 0080 651 228
Country Code: 886		or 0800 33 556
	Corporate Sales	toll free: 0080 651 227

		or 0800 33 555
<b>Thailand</b>	Technical Support	toll free: 0880 060 07
International Access Code: 001	Customer Service (Penang, Malaysia)	604 633 4949
Country Code: 66	Sales	toll free: 0880 060 09
<b>Trinidad/Tobago</b>	General Support	1-800-805-8035
<b>U.K. (Bracknell)</b>	Technical Support (Corporate/Preferred Accounts/PAD [1000+ employees])	0870 908 0500
International Access Code: 00	Technical Support (Direct/PAD and general)	0870 908 0800
Country Code: 44	Global Accounts Customer Care	01344 723186
City Code: 1344	Home and Small Business Customer Care	0870 906 0010
	Corporate Customer Care	01344 72 3185
	Preferred Accounts (500-5000 employees) Customer Care	01344 723196
	Central Government Customer Care	01344 723193
	Local Government Customer Care	01344 723194
	Home/Small Business Sales	0870 907 4000
	Corporate/Public Sector Sales	01344 860456
	Website: <a href="http://support.euro.dell.com">support.euro.dell.com</a>	
	E-mail: <a href="mailto:dell_direct_support@dell.com">dell_direct_support@dell.com</a>	
<b>U.S.A. (Austin, Texas)</b>	Automated Order-Status System	toll free: 1-800-433-9014
International Access Code: 011	AutoTech (For portable and desktop computers)	toll free: 1-800-247-9362
Country Code: 1	<b>Dell Home and Small Business Group</b> (For portable and desktop computers):	
	Customer Technical Support (Return material authorization numbers)	toll free: 1-800-624-9896
	Customer Technical Support (Home sales purchased via <a href="http://www.dell.com">www.dell.com</a> )	toll free: 1-877-576-3355
	Customer Service (Credit return authorization numbers)	toll free: 1-800-624-9897
	<b>National Accounts</b> (Computers purchased by established Dell national accounts [have your account number handy], medical institutions, or value-added resellers [VARs]):	
	Customer Service and Technical Support (Return material authorization numbers)	toll free: 1-800-822-8965
	<b>Public Americas International</b> (Computers purchased by governmental agencies [local, state, or federal] or educational institutions):	
	Customer Service and Technical Support (Return material authorization numbers)	toll free: 1-800-234-1490
	Dell Sales	toll free: 1-800-289-3355 or toll free: 1-800-879-3355
	Spare Parts Sales	toll free: 1-800-357-3355
	Desktop and Portable Fee-Based Technical Support	toll free: 1-800-433-9005
	Sales (Catalogs)	toll free: 1-800-426-5150
	Fax	toll free: 1-800-727-8320
	TechFax	toll free: 1-800-950-1329
	Dell Services for the Deaf, Hard-of-Hearing, or Speech-Impaired	toll free: 1-877-DELLTTY (1-877-335-5889)
	Switchboard	512 338-4400
	DellNet™ Technical Support	toll free: 1-877-Dellnet (1-877-335-5638)
<b>US Virgin Islands</b>	General Support	1-877-673-3355
<b>Venezuela</b>	General Support	8001-3605

[Back to Contents Page](#)